

INCOSA

IC4C TANDEM CRANE SAFETY

EXTENDED CONCEPT

with
IKUSI TM70 tandem remote controls

Version 2

REVISION

Version	Date	Author	Remark
1.0	26/04/10	LP	Basic version
2.0	09/02/11	LP	Modification 2nd generation iC4C firmware

Dit document en de inhoud ervan zijn vertrouwelijk en mogen niet bekendgemaakt worden aan derden zonder uitdrukkelijke toestemming.
The information contained in this document is commercially confidential and must not be disclosed to third parties without prior consent.

CONTENT

1	Project description	3
1.1	General	3
2	Lay-out tandem cranes	4
3	Design architecture	5
4	Definitions	6
4.1	Inputs	6
4.2	Outputs	6
5	System architecture	7
6	Functional description	8
6.1	Safety control	8
6.2	Relay configuration of the safety control	8
6.3	Functions	9
6.3.1	Crane travel	9
6.3.2	Trolley travel	9
6.3.3	Hoist	10
7	Implementation of the iC4C system	11
7.1	Crane functions Crane1	11
7.2	Trolley and hoist functions Crane1	11
7.3	Crane functions Crane2	12
7.4	Trolley and hoist functions Crane2	12
8	Drawings	12

1 Project description

1.1 General

For tandem crane applications, where cranes have to be controlled simultaneously, special safety features must be implemented.

A separate crane is equipped with safety sensors like limit switches, anti-collision sensors, overload sensors, which protects the crane movements like long and longitudinal travel motion and hoist motion. In case of safety detection, one of these motions will be slowed or stopped.

In tandem mode both cranes have to respond simultaneously to unsafe situations. Therefore, the safety status of each crane needs to be communicated in both directions: from crane1 to crane2 and vice versa.

E.g.: in tandem mode, if crane1 reaches the stop limit switch of the long travel track, then crane1 will stop as well as crane2.

The safety signal transmission between the 2 cranes can be performed by a wired link between the cranes. This solution requires a complex wiring job with a lot of modifications into the crane control cabinet and is very time-consuming.

A more practical solution is using a wireless system which transmits the status of each safety sensor between the cranes.

In order to do so, Incosa Solutions developed a wireless intelligent system with iC4C modules that provides an interface between the safety sensors and the crane control. With this system, the implementation of the crane safety for tandem operations will be easier and the safety performances will be more reliable.

The extended concept of this system includes the safety control of the long travel motion of the cranes, the longitudinal travel of the trolley and the hoist movement, which implements slow and limit switches, and the anti-collision detection.

2 Lay-out tandem cranes

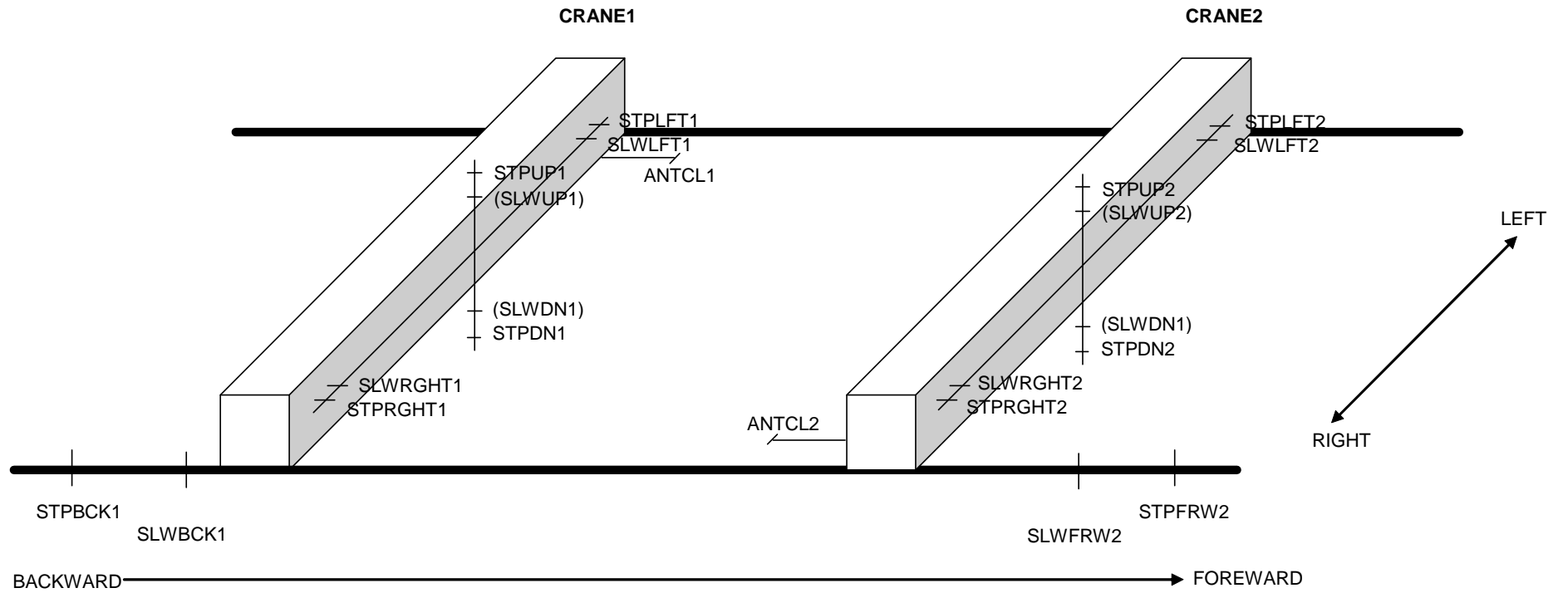

3 Design architecture

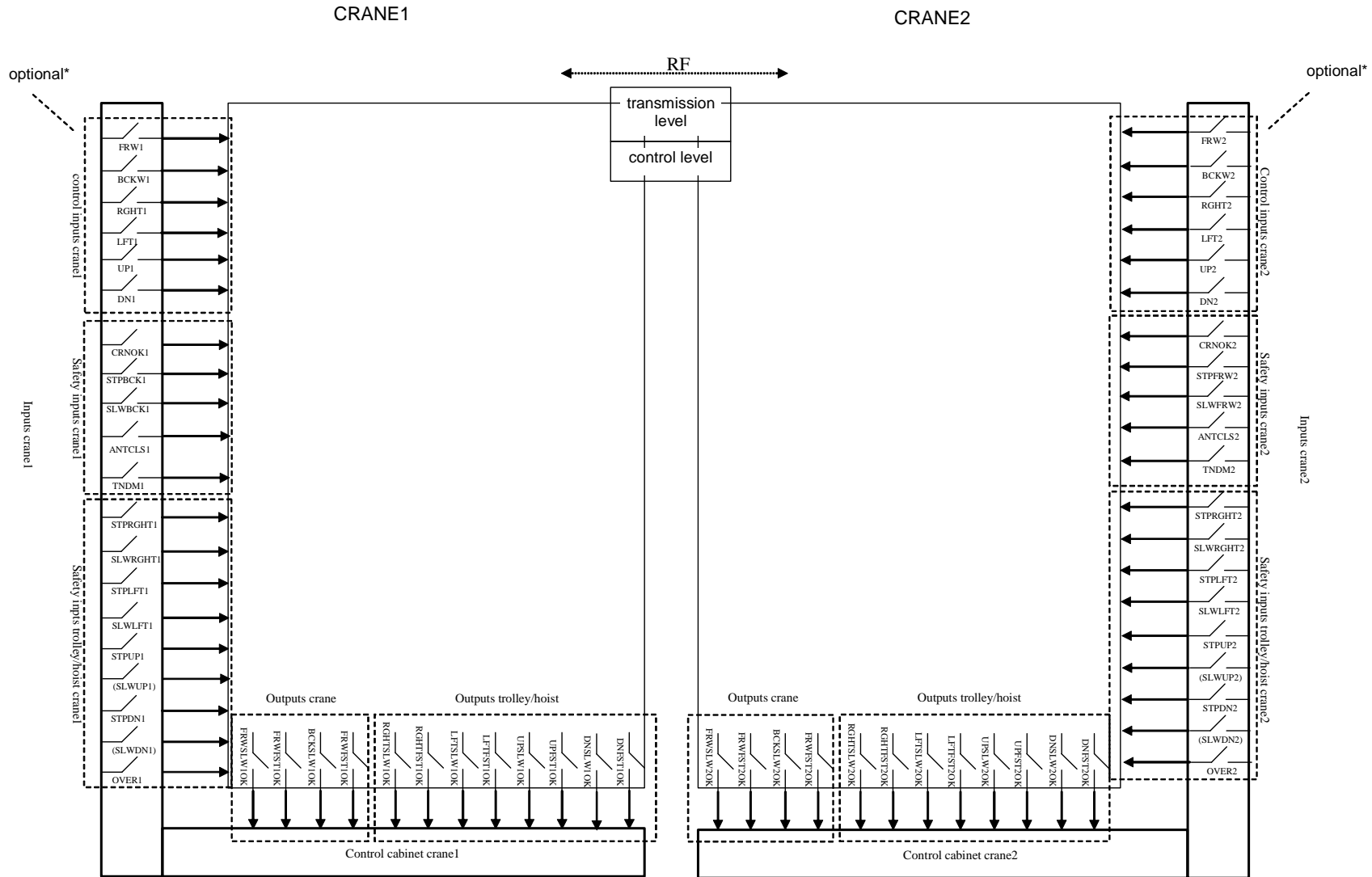

* only necessary if common 2nd speed relay output for the movements

4 Definitions

4.1 Inputs

ANTCLS: anti-collision crane x
 TNDMx: tandem contact x (remote control)
 STPBCKx: stop limit switch crane travel BACKWARD crane x
 STPFRWx: stop limit switch crane travel FORWARD crane x
 SLWBCKx: slow limit switch crane travel BACKWARD crane x
 SLWFRWx: slow limit switch crane travel FORWARD crane x

STPRGHTx: stop limit switch trolley travel RIGHT crane x
 SLWRGHTx: slow limit switch trolley travel RIGHT crane x
 STPLFTx: stop limit switch trolley travel LEFT crane x
 SLWLFTx: slow limit switch trolley travel LEFT crane x
 STPUPx: stop limit switch hoist UP crane x
 (SLWUPx: slow limit switch hoist UP crane x)
 STPDNx: stop limit switch hoist DOWN crane x
 (SLWDNx: slow limit switch hoist UP crane x)
 OVERx: overload contact crane x

REMARKS:

- CRNOKx: input contact from the crane control that indicates crane x is functional: e.g. frequency drive is OK, remote control is OK, etc.; this contact should gather all safety conditions of the crane that cannot be monitored by the iC4C system.
- for movements with a common high speed contact it is necessary to provide extra direction contacts to leave at high speed the slow zones.

OPTIONAL

FRWx: contact crane travel FORWARD (remote control)
 BCKWx: contact crane travel BACKWARD (remote control)
 LFTx: contact trolley travel LEFT (remote control)
 RGHTx: contact trolley travel RIGHT (remote control)
 UPx: contact hoist UP (remote control)
 DNx: contact hoist DOWN (remote control)

These inputs are necessary to leave slow zone at high speed; if these are not provided, the crane will leave the slow zone at low speed

4.2 Outputs

FRWSLWxOK: conditions crane travel FORWARD SLOW SPEED is OK for crane x
 BCKSLWxOK: conditions crane travel BACKWARD SLOW SPEED is OK for crane x
 FRWFSTxOK: conditions crane travel FORWARD HIGH SPEED is OK for crane x
 BCKFSTxOK: conditions crane travel BACKWARD HIGH SPEED is OK for crane x
 LFTSLWxOK: conditions trolley travel LEFT SLOW SPEED is OK for crane x
 RGHTSLWxOK: conditions trolley travel RIGHT SLOW SPEED is OK for crane x
 LFTFSTxOK: conditions trolley travel LEFT HIGH SPEED is OK for crane x
 RGHTFSTxOK: conditions trolley travel RIGHT HIGH SPEED is OK for crane x
 UPSLWxOK: conditions hoist UP SLOW SPEED is OK for crane x
 DNSLWxOK: conditions hoist DOWN SLOW SPEED is OK for crane x
 UPFSTxOK: conditions hoist UP HIGH SPEED is OK for crane x
 DNFSTxOK: conditions hoist DOWN HIGH SPEED is OK for crane x

Optional:

TNDMx: output "TANDEM ACTIVE"

5 System architecture

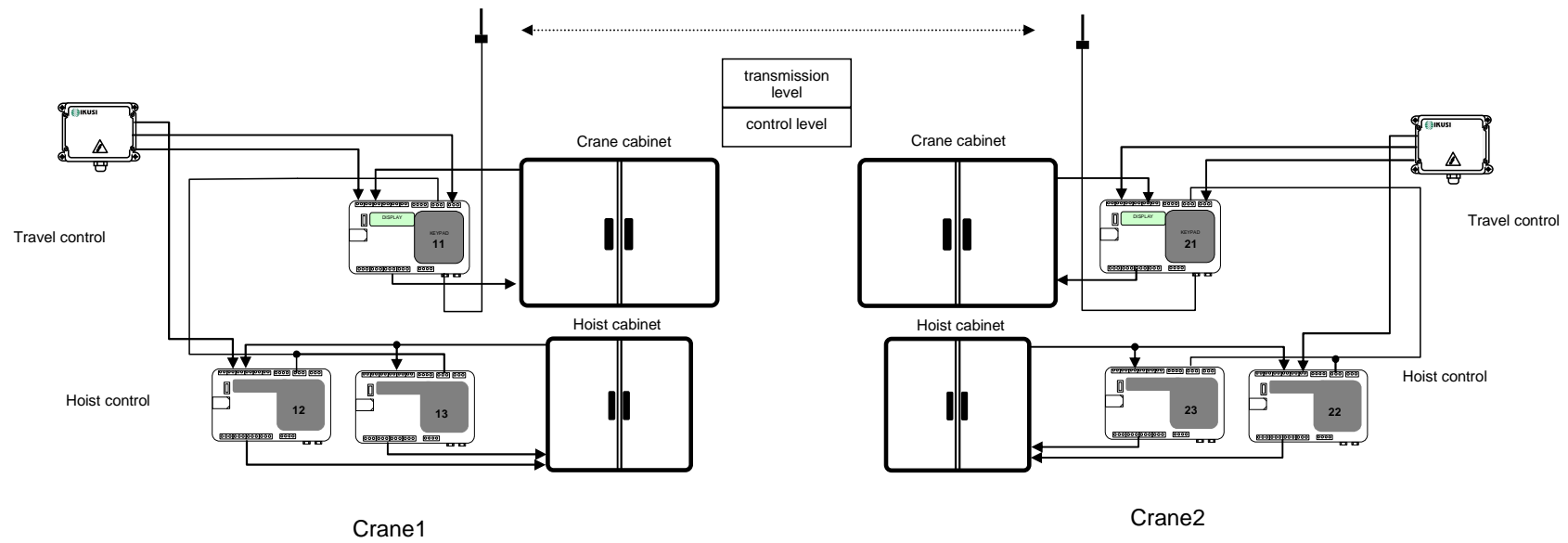

! This layout is only applicable for iC4C systems connected with IKUSI TM70 remote controls through CANbus

6 Functional description

6.1 Safety control

The iC4C system on each crane monitors permanently the status of the safety sensors related to the motions of the crane. If the safety requirements are valid then the iC4C system will allow the corresponding movements of the crane.

In tandem mode, for a safe motion of both cranes, the status of the safety sensors is transmitted between the cranes by means of bidirectional wireless communication.

The iC4C system on each crane monitors following safety items for an optimal safety of the travel movements of the cranes:

- Stop limit switch of the crane and trolley travel and hoist motion
- Slow limit switch of the crane and trolley travel and hoist motion
- Anti-collision of the crane travel
- Valid tandem situation
- Valid operation of the remote control*
- Valid operation of the iC4C modules and their connections (wired and wireless)
- Valid operation of the cranes**

* Only applicable with IKUSI TM70 systems with CAN connection with the iC4C system

** the iC4C system includes an input CRNOKx that needs to be connected to a contact that includes one or more essential safety conditions of the crane functionality: e.g. drive, main contactor, etc. This contact should be closed if all conditions functional conditions of the crane are valid. If this contact is disabled, all movements will be disallowed by the iC4C system for the concerning crane in separate mode as for both cranes in tandem mode.

6.2 Relay configuration of the safety control

a) crane travel

- 2 speeds, 3 relays: $R_{\text{forward slow OK}}$, $R_{\text{backward slow OK}}$, $R_{\text{forward/backward fast OK}}$

b) trolley travel

- 2 speeds, 3 relays: $R_{\text{left slow OK}}$, $R_{\text{right slow OK}}$, $R_{\text{left/right fast OK}}$

c) hoist

- 2 speeds, 3 relays: $R_{\text{up slow OK}}$, $R_{\text{down slow OK}}$, $R_{\text{up/down fast OK}}$

6.3 Functions

6.3.1 Crane travel

Cranes can travel in slow or fast speed, as well in separate mode as in tandem mode.

6.3.1.1 Separated mode

When a crane enters the slow zone, the high speed of crane travel is disabled as long as the crane is moving in the incoming direction of the slow zone. In the outgoing direction of the slow zone the high speed is enabled, if the all other safety requirements are valid and if the direction information (see optional inputs in 4.1 Inputs) of the remote control is known by the iC4C system (through CAN or contact input).

When a crane reaches the stop zone, the travel movement will be stopped in the incoming direction of the stop zone. In the outgoing direction of the stop zone the crane travel movement is allowed if the all other safety requirements are valid.

When a crane enters the anti-collision zone of another crane, the high speed of crane travel is disabled as long as the crane is moving in the incoming direction of the anti-collision zone. In the outgoing direction of the anti-collision zone the high speed is enabled, if the all other safety requirements are valid and if the direction information (see OPTIONAL in 4.1 Inputs) of the remote control is known by the iC4C system (through CAN or contact input).

6.3.1.2 Tandem mode

When one of the tandem cranes enters the slow zone, the high speed travel of both cranes is disabled as long as the crane is moving in the incoming direction of the slow zone. In the outgoing direction of the slow zone the high speed is enabled, if the all other safety requirements are valid and if the direction information (see OPTIONAL in 4.1 Inputs) of the remote control is known by the iC4C system (through CAN or contact input).

When one of the tandem cranes reaches the stop zone, the travel movement of both cranes will be stopped in the incoming direction of the stop zone. In the outgoing direction of the stop zone the crane travel movement is allowed if the all other safety requirements are valid.

In tandem mode, if the all other safety requirements are valid, the anti-collision detection is overruled in order to allow high speed travel of both cranes, even when they are in each other's anti-collision zone.

6.3.2 Trolley travel

Trolley can travel in slow or fast speed, as well in separate mode as in tandem mode.

6.3.2.1 Separated mode

When a trolley enters the slow zone, the high speed of trolley travel is disabled as long as the trolley is moving in the incoming direction of the slow zone. In the outgoing direction of the slow zone the high speed is enabled, if the all other safety requirements are valid and if the direction information (see optional inputs in 4.1 Inputs) of the remote control is known by the iC4C system (through CAN or contact input).

When a trolley reaches the stop zone, the travel movement will be stopped in the incoming direction of the stop zone. In the outgoing direction of the stop zone the trolley travel movement is allowed if the all other safety requirements are valid.

6.3.2.2 Tandem mode

When one trolley of the tandem cranes enters the slow zone, the high speed travel of the trolley of both cranes is disabled as long as the trolley is moving in the incoming direction of the slow zone. In the outgoing direction of the slow zone the high speed is enabled, if the all other safety requirements are valid and if the direction information (see OPTIONAL in 4.1 Inputs) of the remote control is known by the iC4C system (through CAN or contact input).

When one trolley of the tandem cranes reaches the stop zone, the travel movement of the trolley of both cranes will be stopped in the incoming direction of the stop zone. In the outgoing direction of the stop zone the trolley travel movement is allowed if the all other safety requirements are valid.

6.3.3 Hoist

Trolley can lift or lower in slow or fast speed, as well in separate mode as in tandem mode.

6.3.3.1 Separated mode

When the hook of the hoist enters the slow zone, the high speed of hoist motion is disabled as long as the hook is moving in the incoming direction of the slow zone. In the outgoing direction of the slow zone the high speed is enabled, if the all other safety requirements are valid and if the direction information (see optional inputs in 4.1 Inputs) of the remote control is known by the iC4C system (through CAN or contact input).

When the hook of the hoist reaches the stop zone, the hoist movement will be stopped in the incoming direction of the stop zone. In the outgoing direction of the stop zone the hook movement is allowed if the all other safety requirements are valid.

6.3.3.2 Tandem mode

When one hook of the tandem cranes enters the slow zone, the high speed travel of the hook of both cranes is disabled as long as the trolley is moving in the incoming direction of the slow zone. In the outgoing direction of the slow zone the high speed is enabled, if the all other safety requirements are valid and if the direction information (see OPTIONAL in 4.1 Inputs) of the remote control is known by the iC4C system (through CAN or contact input).

When one hook of the tandem cranes reaches the stop zone, the hoist movement of the hook of both cranes will be stopped in the incoming direction of the stop zone. In the outgoing direction of the stop zone the hook movement is allowed if the all other safety requirements are valid.

7 Implementation of the iC4C system

7.1 Crane functions Crane1

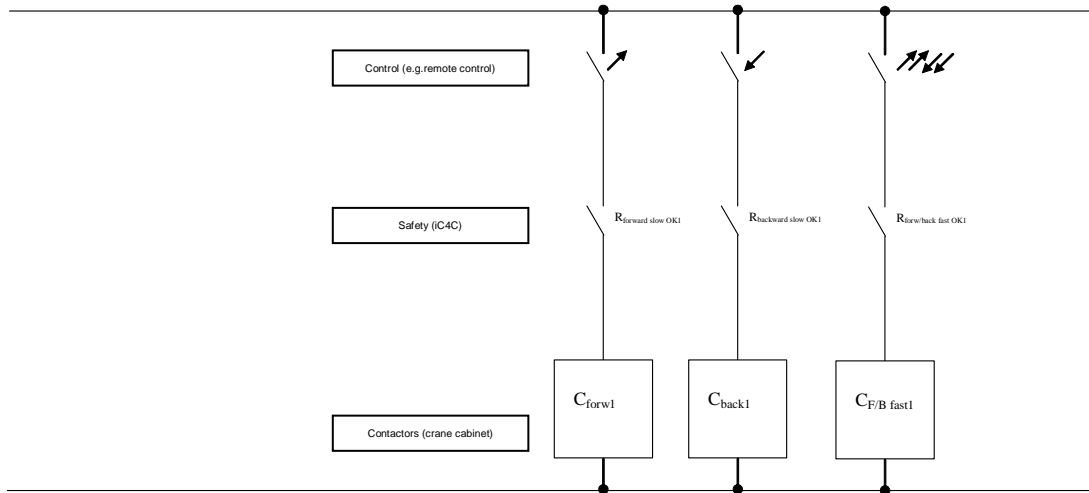

7.2 Trolley and hoist functions Crane1

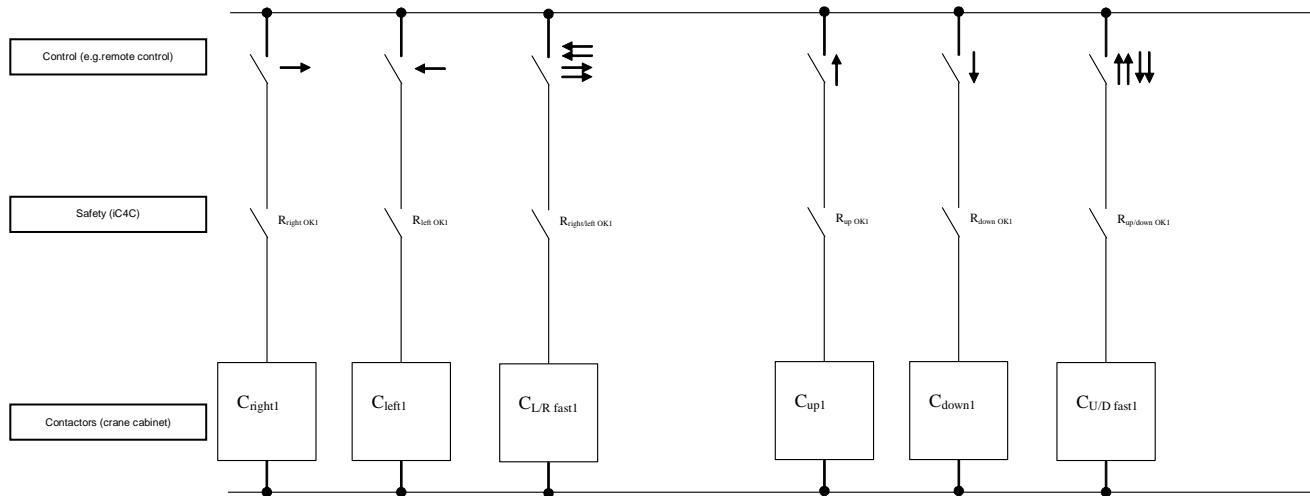

7.3 Crane functions Crane2

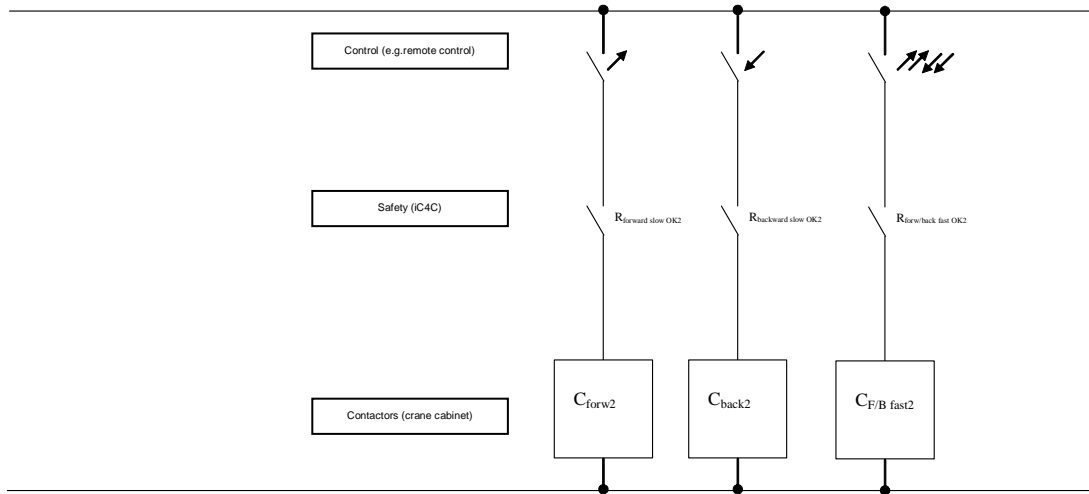

7.4 Trolley and hoist functions Crane2

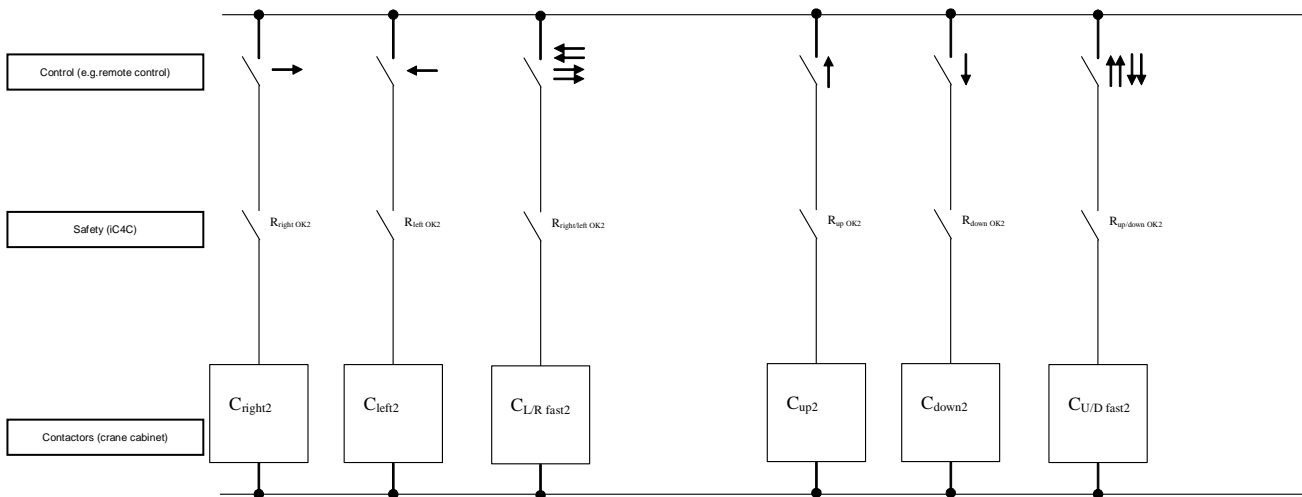

8 Drawings

The connection configuration of the contact inputs is crane dependent. Use the correct connection drawings for the right crane!

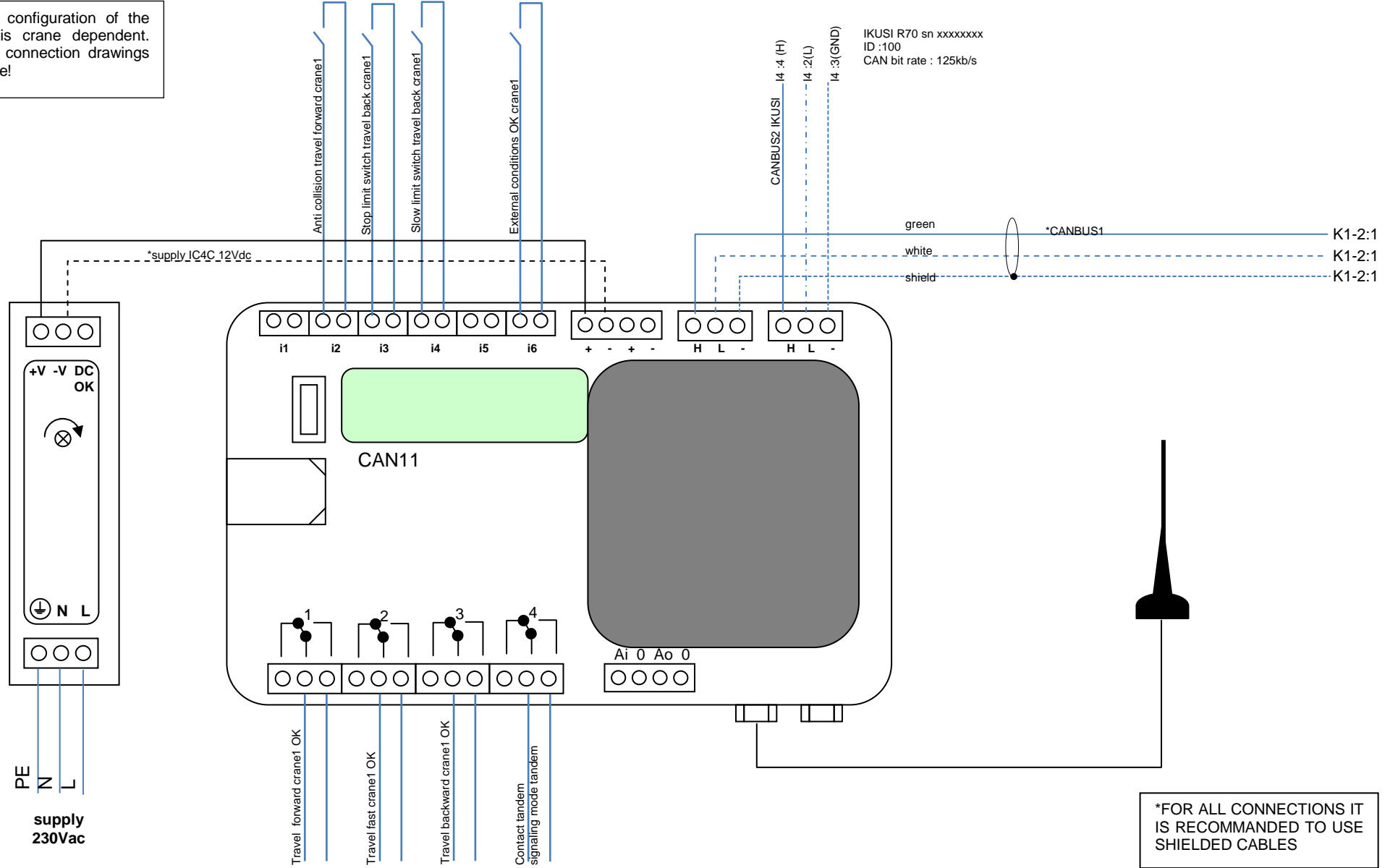

*FOR ALL CONNECTIONS IT IS RECOMMENDED TO USE SHIELDED CABLES

The connection configuration of the contact inputs is crane dependent. Use the correct connection drawings for the right crane!

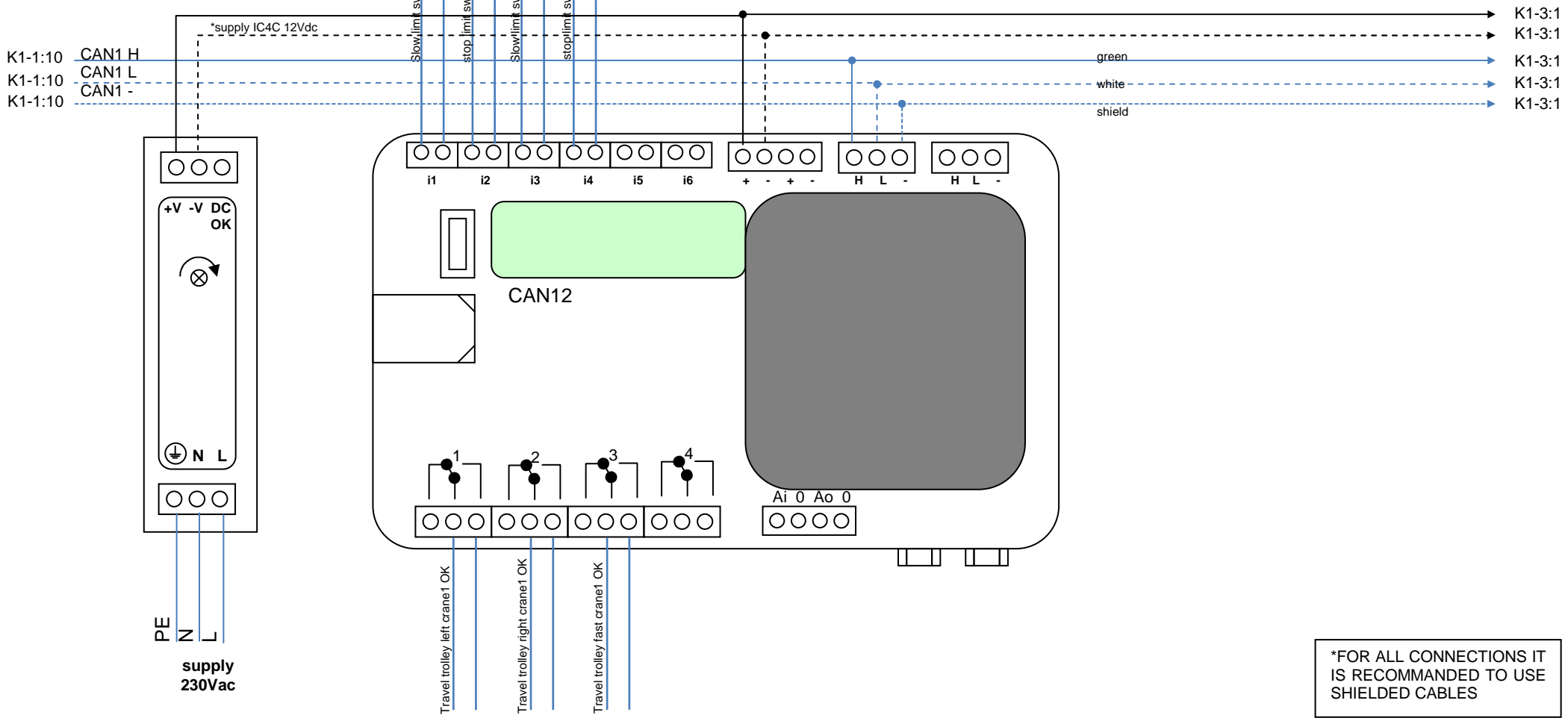

The connection configuration of the contact inputs is crane dependent. Use the correct connection drawings for the right crane!

K1-2:10 +12Vdc
 K1-2:10 0Vdc
 K1-2:10 CAN1 H green
 K1-2:10 CAN1 L white
 K1-2:10 CAN1 - shield

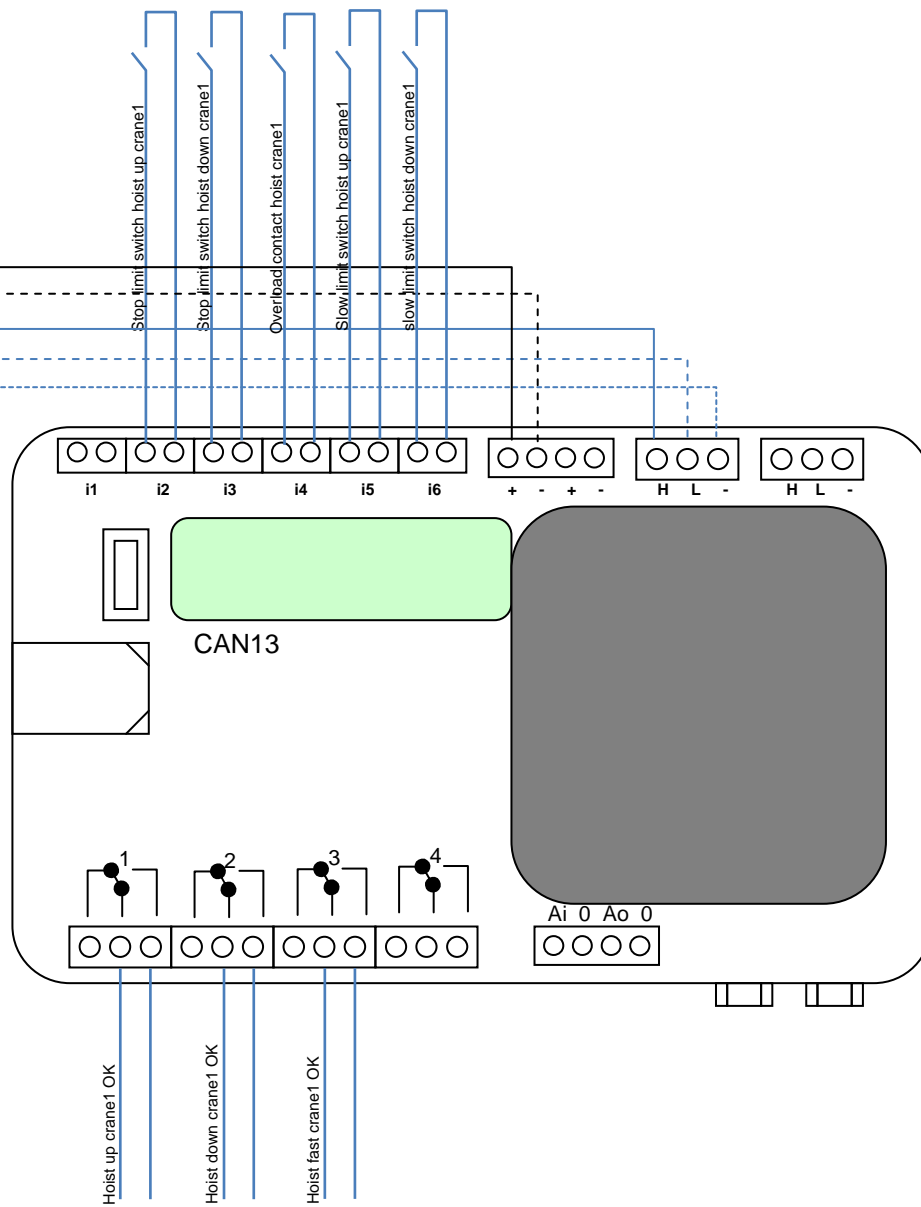

*FOR ALL CONNECTIONS IT IS RECOMMENDED TO USE SHIELDED CABLES

The connection configuration of the contact inputs is crane dependent. Use the correct connection drawings for the right crane!

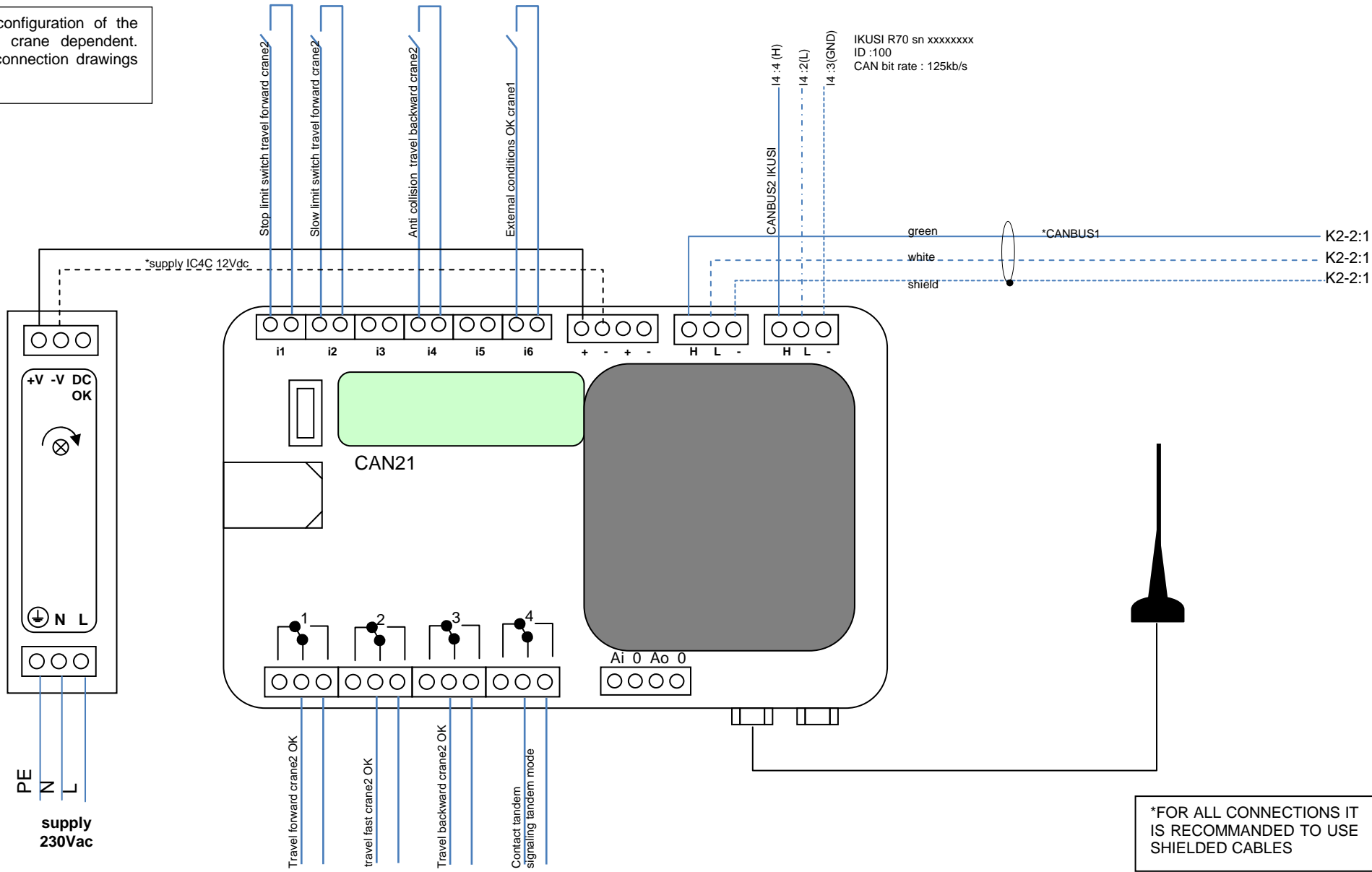

supply

i-c4c

The connection configuration of the contact inputs is crane dependent. Use the correct connection drawings for the right crane!

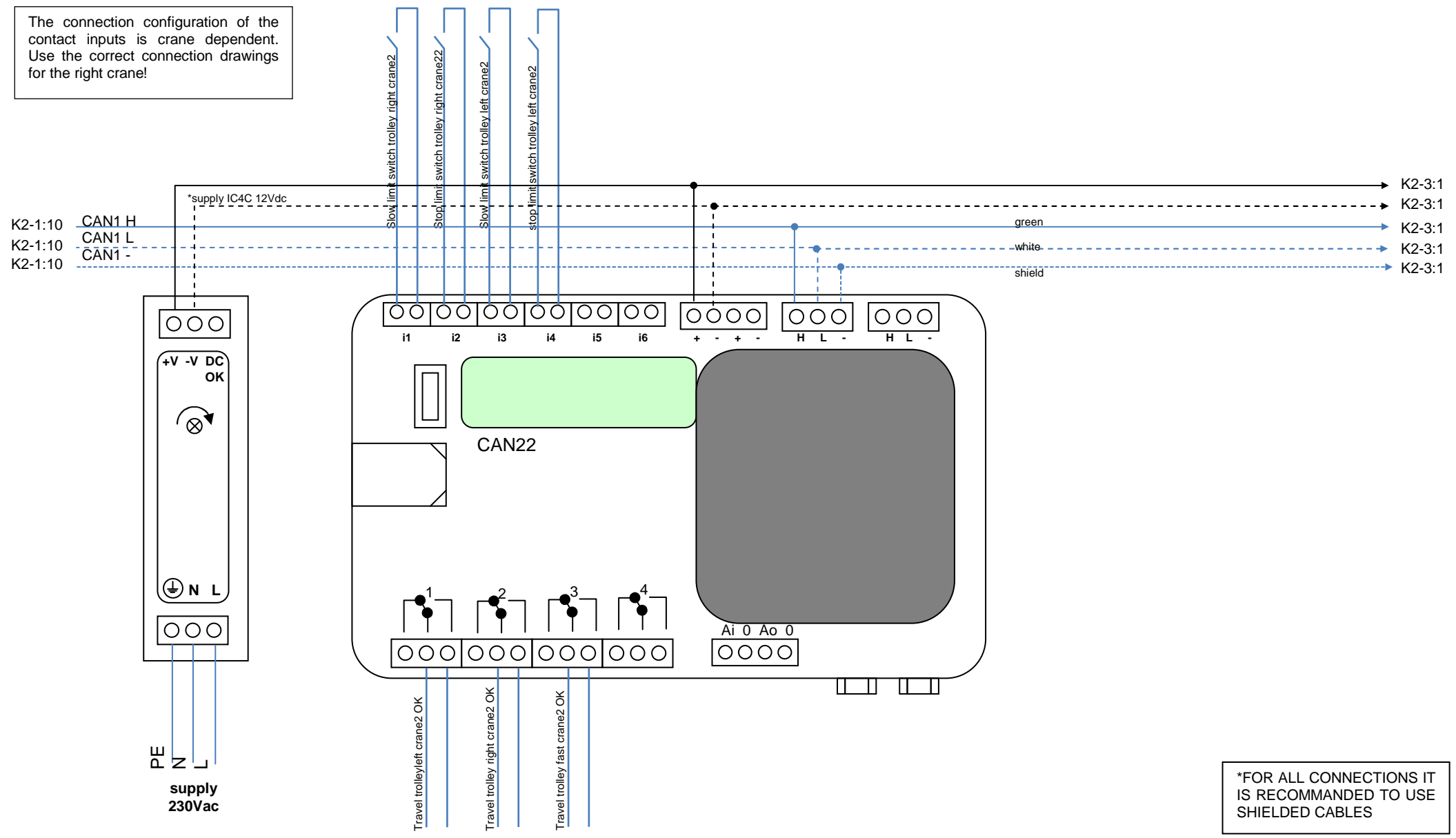

The connection configuration of the contact inputs is crane dependent. Use the correct connection drawings for the right crane!

K2-2:10 +12Vdc
 K2-2:10 - 0Vdc
 K2-2:10 CAN1 H green
 K2-2:10 CAN1 L white
 K2-2:10 CAN1 - shield

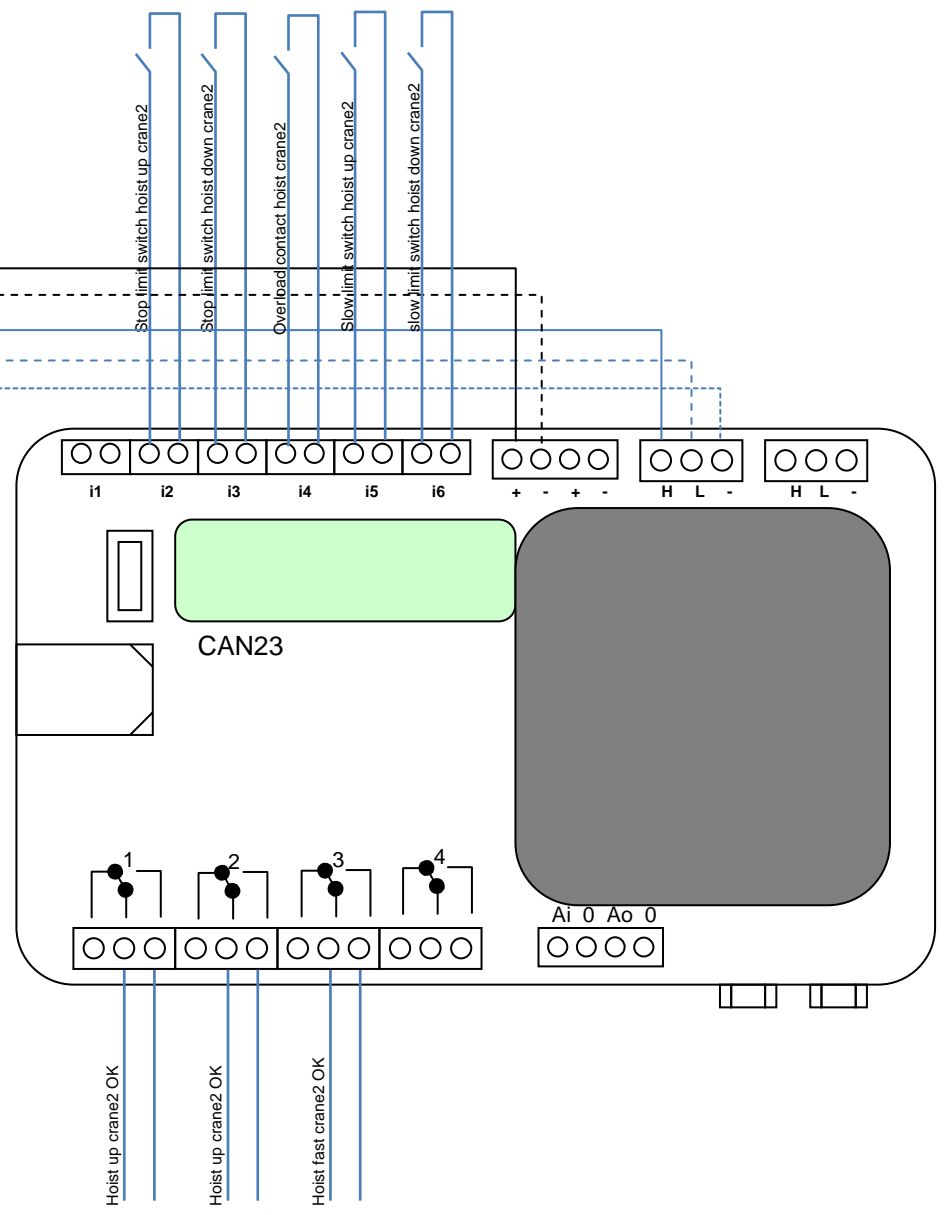

*FOR ALL CONNECTIONS IT IS RECOMMENDED TO USE SHIELDED CABLES

CABLE CAN

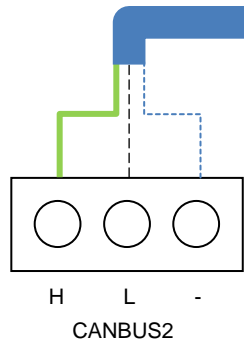
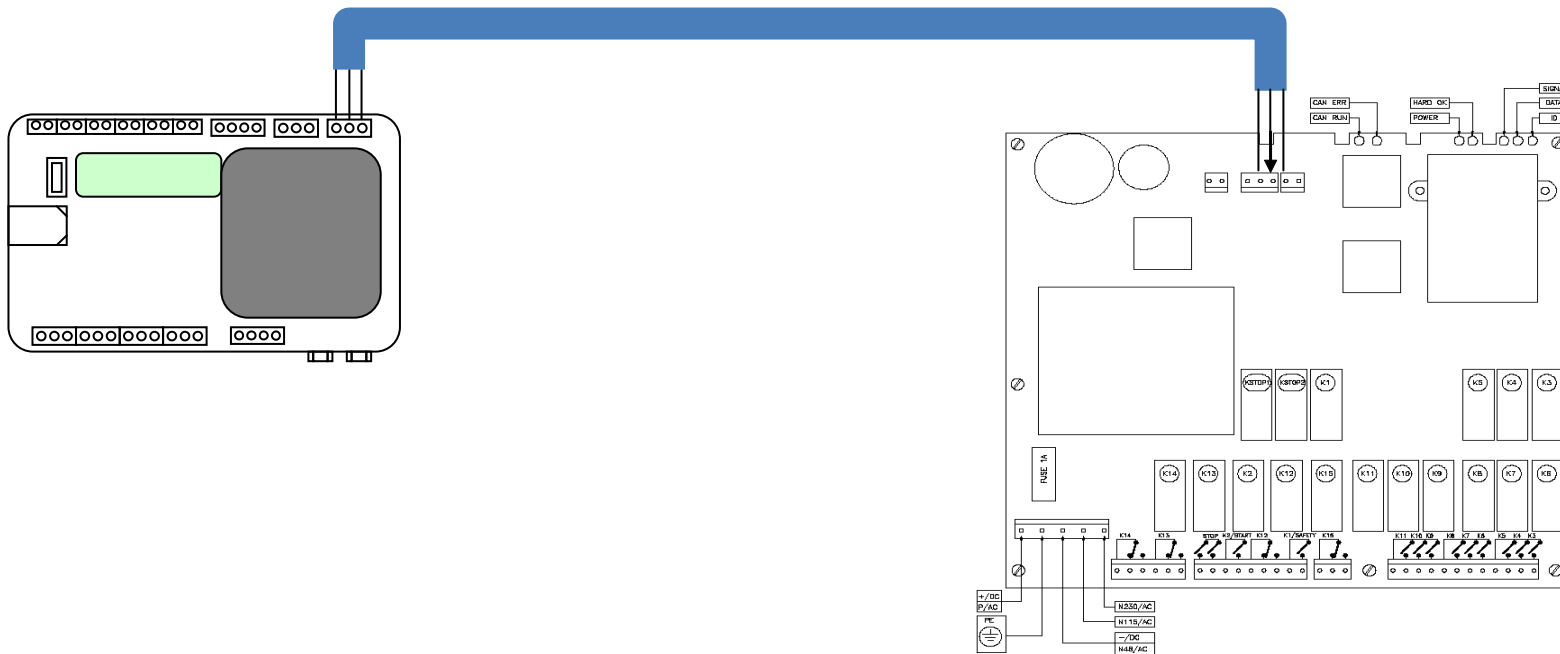

Color codes CAN cable

- H: green
- L: white
- : shield

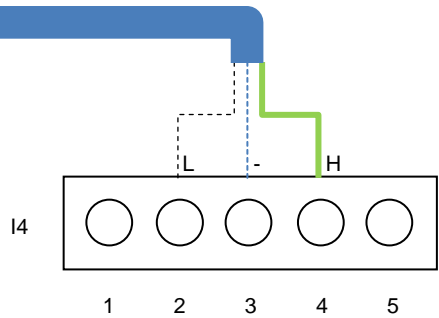

- 1: GND
- 2: CAN L
- 3: GND
- 4: CAN H
- 5: V+

*FOR ALL CONNECTIONS IT IS RECOMMENDED TO USE SHIELDED CABLES