

MANUAL

i·C4C GO

Generation OEM

V0 - 10/2022

1 Table of contents

1	Table of contents.....	2
2	General	3
3	Overview	4
4	Description	5
5	Installation.....	6
5.1	Dimensions	6
5.2	Instructions	7
5.3	Wireless antenna	8
6	Connections	9
6.1	Supply.....	10
6.1.1	Standard power adaptor	10
7	Webpage.....	11
7.1	Connection.....	11
7.2	Home (User)	11
7.3	Flash parameters (User/Dealer)	12
7.4	Setup (User)	13
7.5	Log (User).....	14
7.6	Login.....	15
7.7	Home (OEM/Dealer) – Additional functionality.....	15
7.8	Flash parameters (OEM)	16
7.9	Setup (OEM/Dealer)	17
7.9.1	Change parameters – manually.....	17
7.9.2	Change parameters – automatically	18
7.10	Log (OEM/Dealer)	19
7.11	Firmware (OEM/Dealer)	20
7.11.1	Upload firmware	21
8	Communication	22
8.1	Architecture.....	22
8.1.1	Wired (CAN)	22
8.1.2	Wireless (Wifi)	23
9	Technical specifications	24
9.1	General data	24
9.2	Electrics/electronics	24
9.3	Mechanical data.....	25
9.4	Ambient data.....	25
10	Annexe.....	26
10.1	Load cells	26
10.1.1	Connection	26
10.1.2	Load limiter on rope.....	26
10.1.3	Load cell flexion	27
10.1.4	Double shear Load Pin.....	28
10.2	µCAN Converter	29
10.3	Antennas	30
10.3.1	Standard magnetic antenna 2dB	30
10.3.2	Panel Directional Antenna 12dB	31

2 General

The i-C4C GO PRO is our new generation cutting-edge controller offering fully integrated hoisting equipment intelligence. It features separate processors (MCUs) for general functionality and overload protection, for which it is Performance Level d certified – exceeding the requirements of EN 14492-2 and ISO 13849-1:2015.

It is a fully integrated controller for your crane hoisting equipment, combining customized functionality with certified safety. The human interface of your choice is connected via Wi-Fi.

The i-C4C GO BASIC is the limited version of the i-C4C GO PRO, usable as controller where the safety certification and the extra connectivity is not required.

3 Overview

The product covered by this manual is the **i-C4C GO**. This document provides an overview of the installation, configuration and use of this device.

The **i-C4C GO** is available in two main models: pro and basic. The human interface of for both models is via Wi-Fi.

The PRO model has as overload protection, for which it is Performance Level d certified – exceeding the requirements of EN 14492-2 and ISO 13849-1:2015. In the near future it will also be possible to communicate over MODBUS or ETHERNET/IP and to send logging data directly to the cloud, using its CLOUD CONNECT interface. The BASIC model is the limited version of the i-C4C GO PRO, usable as controller where the safety certification and the extra connectivity is not required.



HARDWARE	PRO	BASIC
PLd certified overload protection	✓	✗
Ethernet port	✓	✗
22/12 I/O	✓	✓
Wi-Fi	✓	✓
CAN	✓	✓
0-10V	✓	✓
Cloud connect	✓	✗

By default, the **i-C4C GO** is configured as a load limiter. Given the numerous variations of possibilities concerning the connections and software configurations, this document will handle the default application of the **i-C4C GO**.

All other application configurations will be detailed in the production file of each custom made system.

4 Description

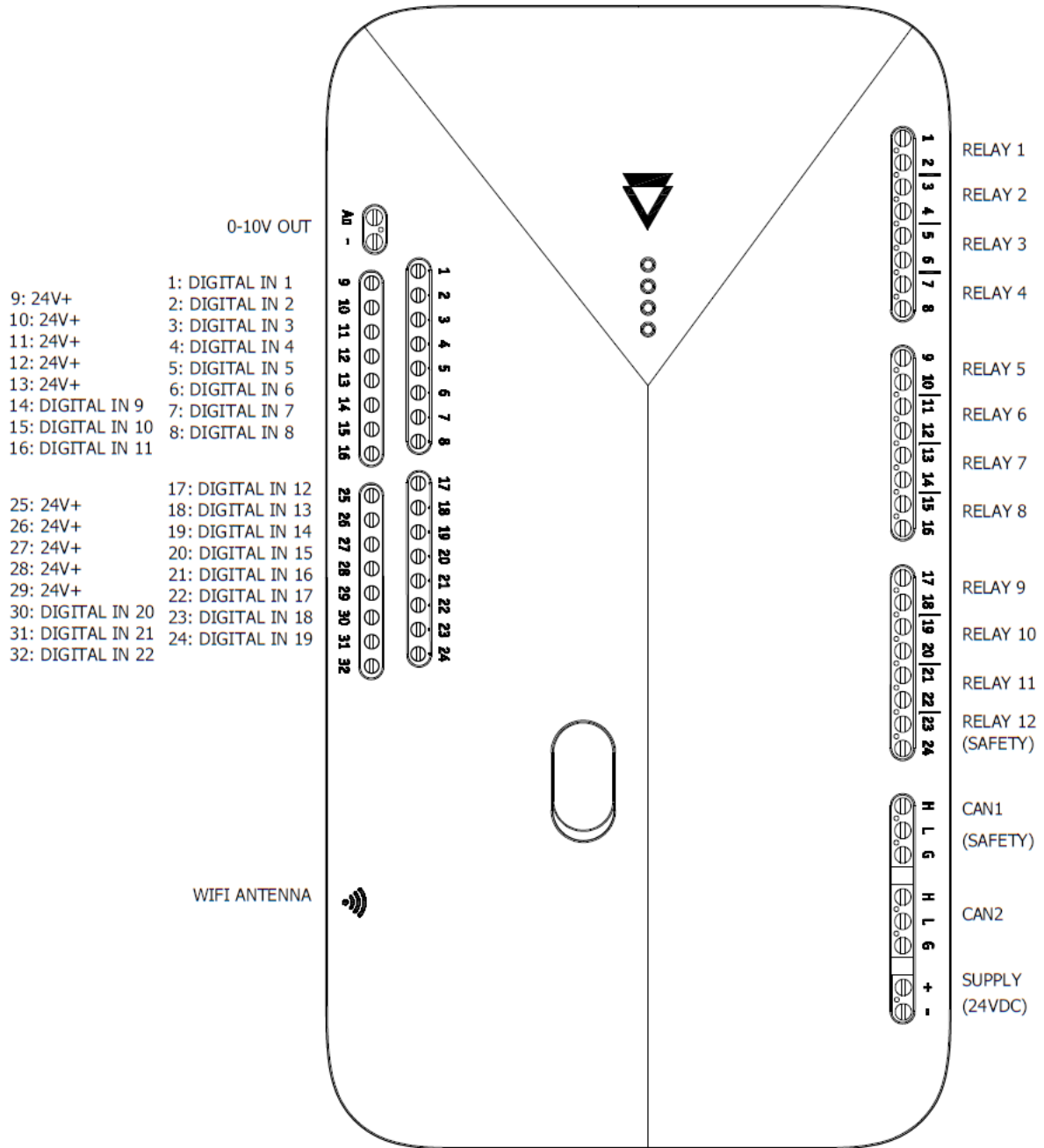

5 Installation

Follow the instructions as described in this manual for the installation of this product.

5.1 Dimensions

The following diagram shows the dimensions for the **i-C4C GO**.

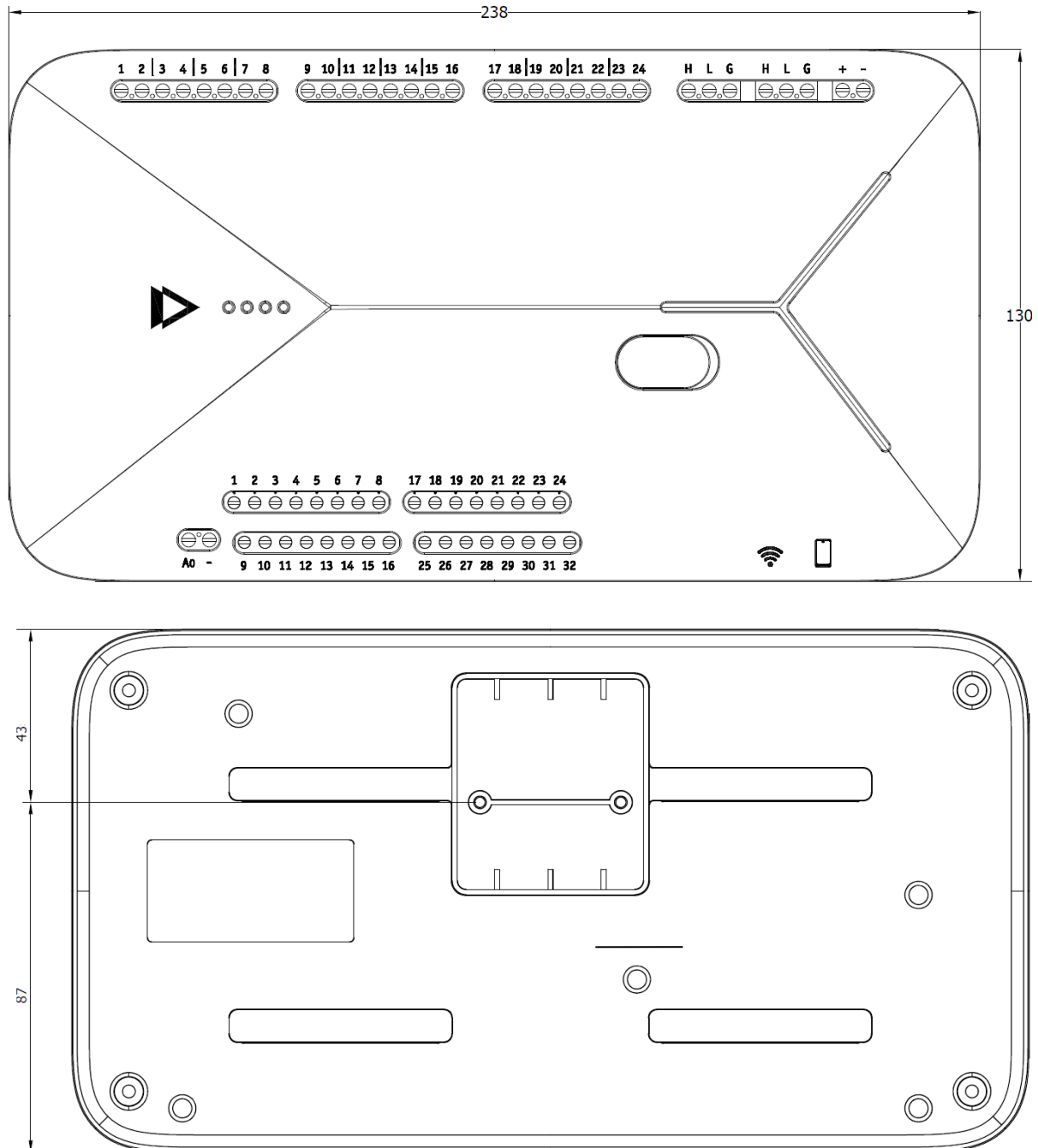

Figure 1: mounting dimensions i-C4C GO on DIN rail

5.2 Instructions

- Turn off the power supply.
- Locate a suitable and accessible place to install the **i-C4C GO**, away from any devices that produces strong electro-magnetic fields.
- Connect the power supply cable to the **i-C4C GO**.
- Connect the input and output cables to the corresponding connectors according the connection diagram.
- Connect the CAN communication cable(s) to the corresponding CAN interfaces according the connection diagram.
- Install the cables (inputs, outputs, communication) away from power cables.



It is advised to use shielded cables for the inputs, outputs and communication connections.



It is advised to respect a distance of at least 200mm between the i-C4C GO cables (inputs, outputs, communication) and power cables 230Vac/380Vac 50/60Hz. A greater distance is indicated for larger power and/or high frequency.

5.3 Wireless antenna

Optional, the **i-C4C GO** can be configured for wireless communication with a display. By means of the magnetic foot, the antenna can easily be installed on any magnetic metal surfaces.

For optimal communication you need to locate the antennas of the wireless modules according these recommendations.

- Line of sight

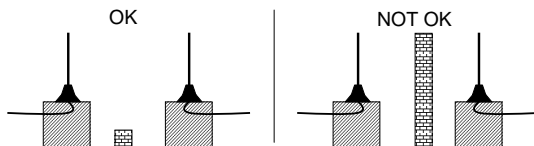

- Pointing up

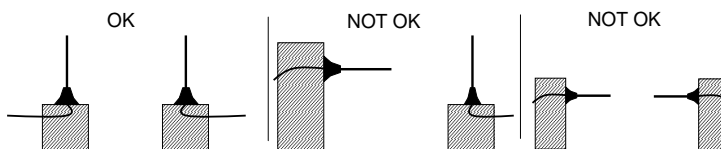

- Free surrounding

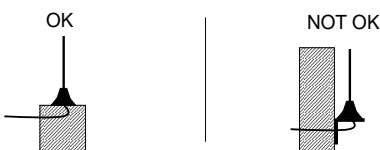

- Max range*: 50m (with standard antenna)



*Wireless communication performance depends on many factors, conditions and variables, including building materials and construction, mix of wireless products used, interference and other adverse conditions, which can affect the wireless signal range.

6 Connections

There are several rules that must be followed when wiring the **i-C4C GO**. Recommendations, when needed, are provided on how to comply with the rules.

DANGER

ELECTRIC SHOCK

- Be sure to remove ALL power from ALL devices before connecting or disconnecting inputs or outputs to any terminal or installing or removing any hardware.
- Be sure to connect the grounding wire to a proper ground.

Failure to follow this instruction will result in death, serious injury, or equipment damage.

WARNING

FAILURE OF OUTPUTS

- If outputs should fail, outputs may remain on or off. Where personnel and or equipment hazards exist, use appropriate safety interlocks.

Failure to follow this instruction can result in death, serious injury, or equipment damage.

- Each terminal accepts wires from 26 AWG (0,13 mm²) up to 14 AWG (2.08 mm²) fitted with cable ends or tags.
- Depending on the load, a protection circuit may be needed for relay outputs on modules.
- The power supply wire should be between 26 AWG (0.13 mm²) and 14 AWG (2.08 mm²). Use the shortest wire length possible.
- Incorrect wiring can cause equipment damage.
- Make sure that the operating conditions and environments are within the specification values.
- Use proper wire size to meet voltage and current requirements.

6.1 Supply

The main supply of the **i-C4C GO** is 24VDC. For other supply voltages, a power adaptor will be needed to convert the available supply voltage into 24VDC.

6.1.1 Standard power adaptor

Mornsun LI30-20B24PR2

- Input voltage: 100-240V AC (0.9A, 50-60Hz)
- Output voltage: 24V DC (1.5A)
- Short circuit protection

Please refer to your dealer/retailer for appropriate power adaptor.

7 Webpage

7.1 Connection

Connect to the Access point of the **i-C4C GO**.

SSID: IC4Cxxxxxxxx

Contact your supplier for the password.

7.2 Home (User)

Open a webbrowser and go to the address: 192.168.1.1.

Here you have an overview of the current state of the IO of the **i-C4C GO**

The screenshot shows a web browser window with the URL http://192.168.1.1. The page features the 'incosa solutions' logo and a navigation menu on the left with options: Home, Flash parameters, Setup, Log, and Login. The main content area is titled 'Status' and displays several data points:

- Loadcell state:** Ok
- Gross load:** 2068
- Digital output:** A table with columns 1-11 and Safety. Values are 0 for 1-11 and 1 for Safety.
- Digital inputs:** A table with columns 1-22. Values are 0 for 1-10, 1 for 11-12, 0 for 13-15, 1 for 16, 0 for 17, 1 for 18, 0 for 19, 0 for 20, 0 for 21, and 1 for 22.
- Analog output:** 5825
- Remaining SWP value:** 3198

Below the status section is a 'Date & time' section with the following data:

Date	27-10-2022
Time	15:21:03
Deviation (s)	3

At the bottom of the page, there is a status bar showing 'Connected' on the left and 'Version 0.1 (User)' on the right.

7.3 Flash parameters (User/Dealer)

You can find the serial number, hoist configuration and CAN settings. The configuration and CAN-settings can be changed from the OEM level.

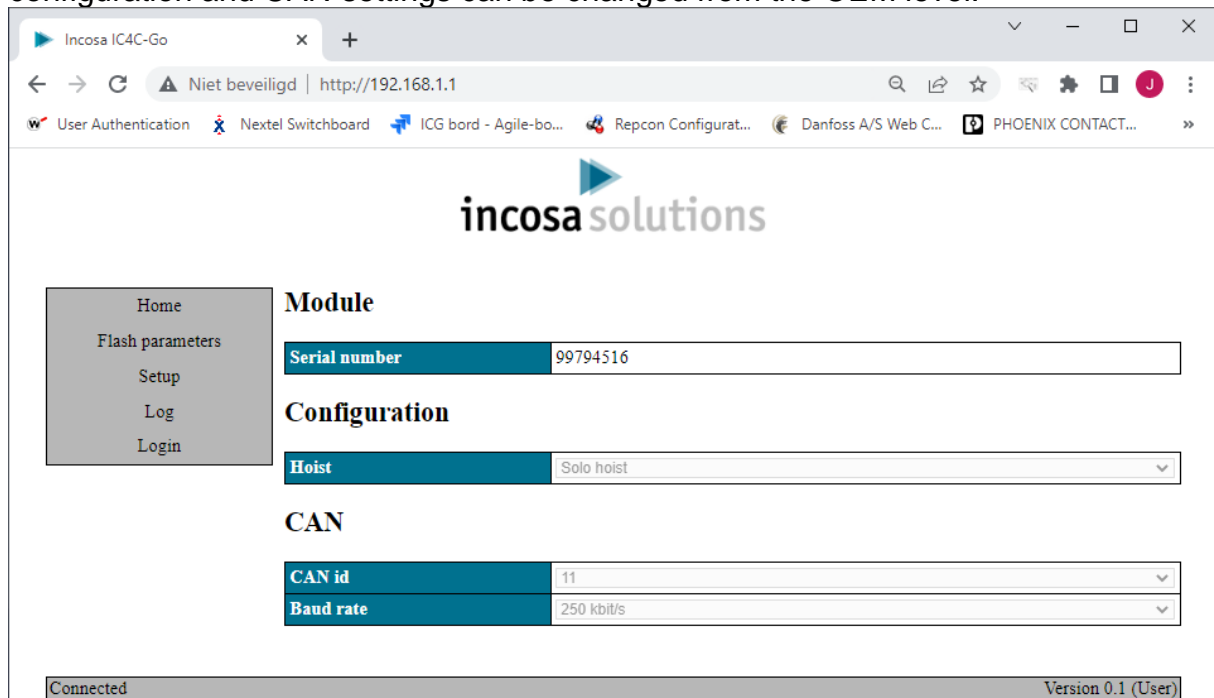

The screenshot shows a web browser window with the URL `http://192.168.1.1`. The page header features the **incosa solutions** logo. On the left, a navigation menu includes: Home, Flash parameters (selected), Setup, Log, and Login. The main content area is divided into three sections:

- Module**: A table with one row:

Serial number	99794516
---------------	----------
- Configuration**: A table with one row:

Hoist	Solo hoist
-------	------------
- CAN**: A table with two rows:

CAN id	11
Baud rate	250 kbit/s

At the bottom of the page, a status bar shows "Connected" on the left and "Version 0.1 (User)" on the right.

7.4 Setup (User)

Here you can find an overview of all parameters. You have to be logged in to be able to change them.

The screenshot shows the 'Parameters' page in the Incosa IC4C-Go web interface. The page is titled 'Parameters' and features a navigation menu on the left with options: Home, Flash parameters, Setup, Log, and Login. The main content area is divided into four sections, each containing a table of parameters:

- Safety Parameters:**

Loadcell CAN id	1
Loadcell cable diameter (mm)	0
Load measurement offset (kg)	0
Gain (-)	2000
Overload value (kg)	3300
Overload hysteresis (%)	50
Overload delay (ms)	200
Loadcell capacity (kg)	2000
Hoist capacity (kg)	3000
Additional gain factor (-)	1
- Display parameters:**

Refresh time (s)	1
Value deviation	1
Resolution	100
Decimal shift	100
- SWP Parameters:**

Safe Working Period (Start value) (h)	3200
---------------------------------------	------
- Configuration Parameters:** (This section is currently empty in the screenshot)

The status bar at the bottom of the page indicates 'Connected' on the left and 'Version 0.1 (User)' on the right.

7.5 Log (User)

You can download the logging file of the **i-C4C GO**. You have to upload the logging file on the following site to generate an csv-file: <https://www.ic4cgolog.com/>

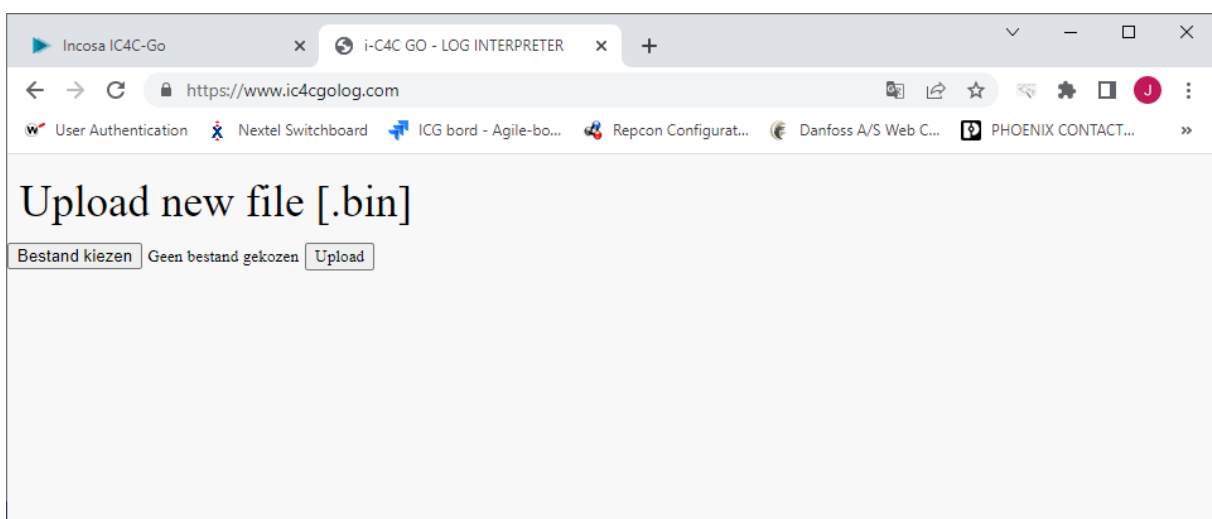
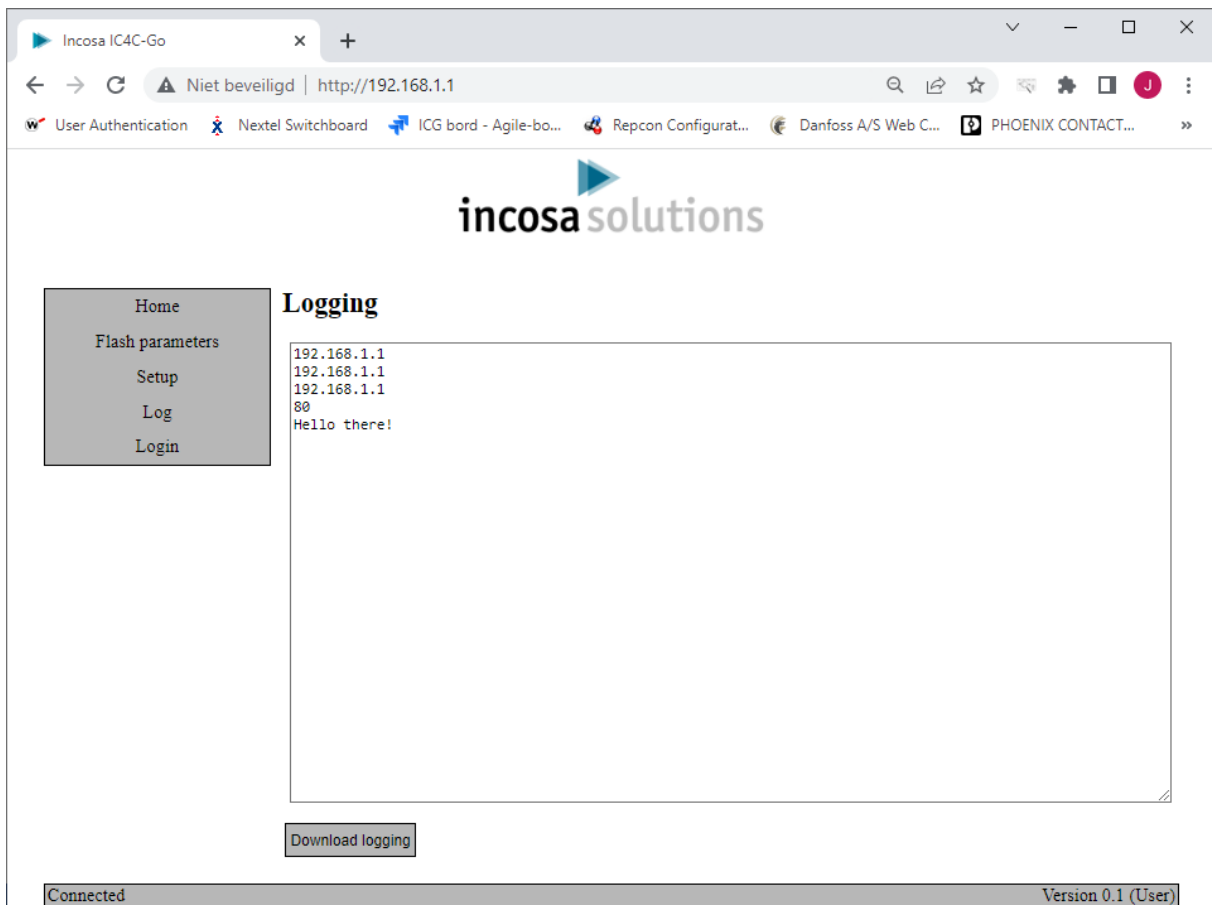

7.6 Login

Some additional functionality on the **i-C4C GO** requires a login (e.g. change parameters, upload program,...). There are two possible login accounts: check your specification sheet for your login credentials.

- Username:
 - dealer
 - oem

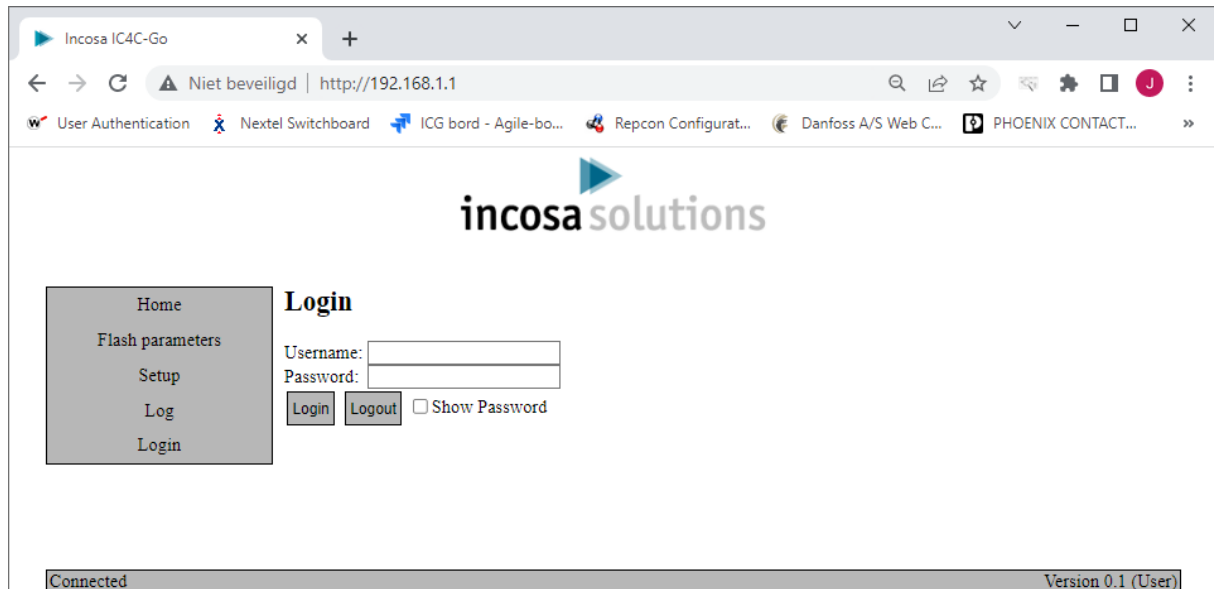

7.7 Home (OEM/Dealer) – Additional functionality

Additional functionality:

- Synchronise time: this button can be used to set the internal clock of the **i-C4C GO** to the same value as the connected device. You can use the **Deviation** field as reference.

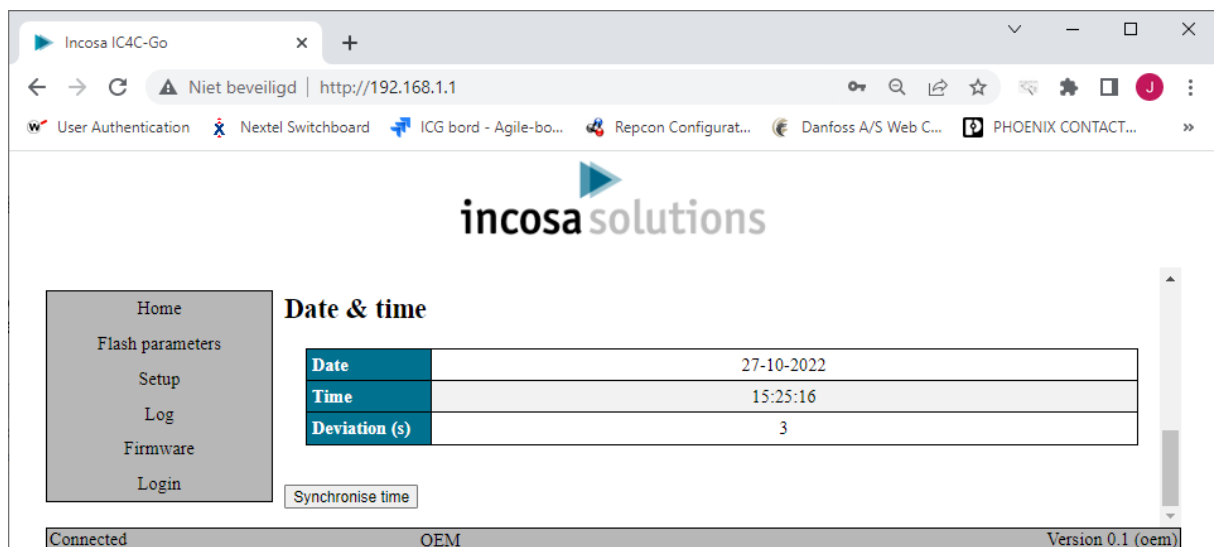

7.8 Flash parameters (OEM)

Additional functionality:

- Change hoist configuration (solo hoist/multi hoist)
- Change CAN id
- Change CAN baudrate

The screenshot shows a web browser window with the URL <http://192.168.1.1>. The page features the 'incosa solutions' logo at the top center. On the left, a navigation menu includes 'Home', 'Flash parameters', 'Setup', 'Log', 'Firmware', and 'Login'. The main content area is titled 'Module' and contains a 'Serial number' field with the value '99794516'. Below this is a 'Configuration' section with a 'Hoist' dropdown menu set to 'Solo hoist'. The 'CAN' section includes a 'CAN id' dropdown set to '11' and a 'Baud rate' dropdown set to '250 kbit/s'. A 'Write & reboot' button is located below these fields. At the bottom of the page, a status bar shows 'Connected', 'OEM', and 'Version 0.1 (oem)'.

7.9 Setup (OEM/Dealer)

Additional functionality

- Change parameter values
 - Manually
 - Automatic: offset
 - Automatic: gain

7.9.1 Change parameters – manually

You can change parameters by entering new values and confirming these values using the **Write**-button under each section. There are some additional restriction for the Safety parameters, which are described on the next page.

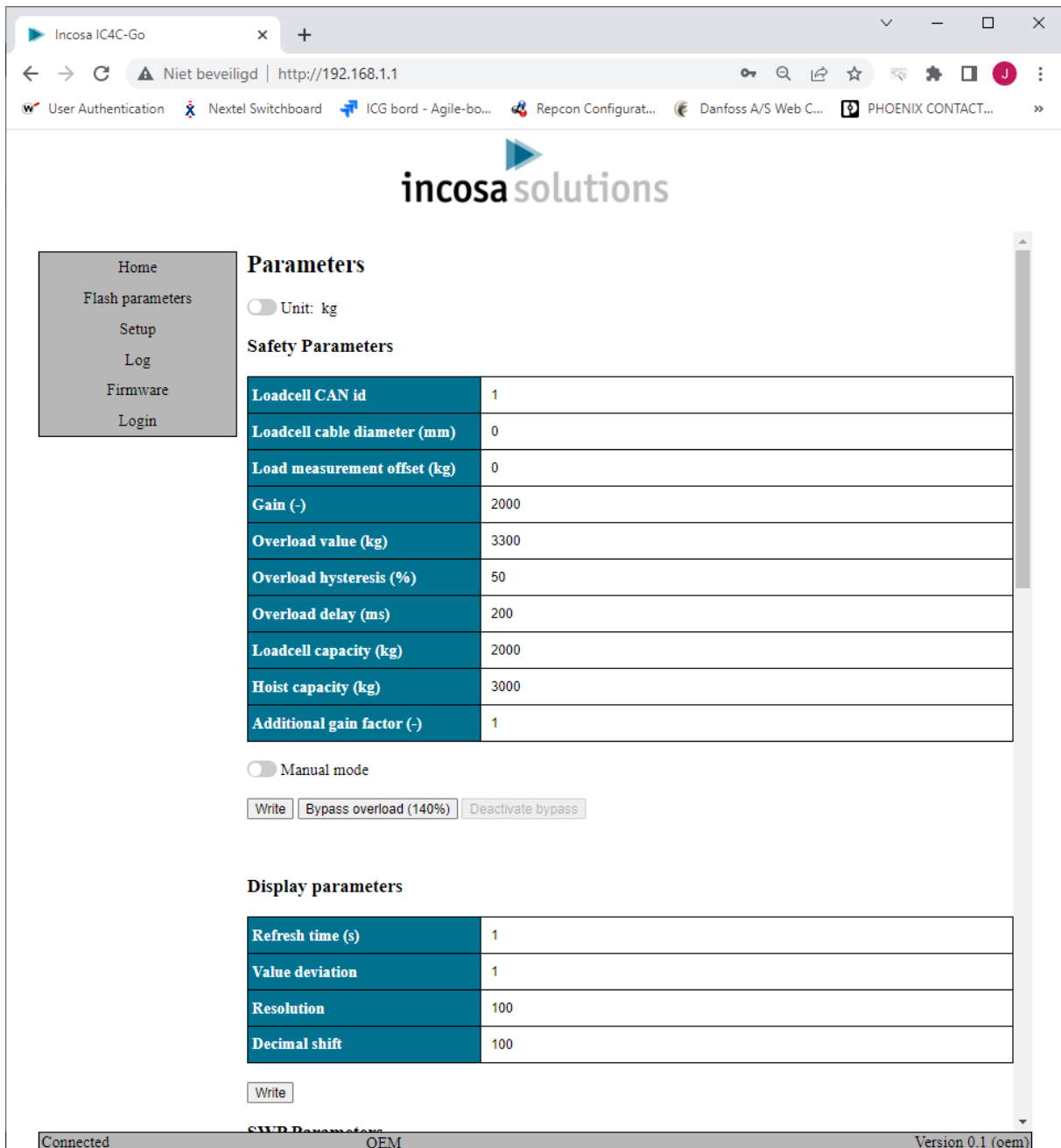

The screenshot shows the 'Parameters' page in the Incosa IC4C-Go web interface. The browser address bar shows 'http://192.168.1.1'. The page features a navigation menu on the left with options: Home, Flash parameters, Setup, Log, Firmware, and Login. The main content area is titled 'Parameters' and includes a 'Unit: kg' toggle switch. Below this is the 'Safety Parameters' section, which contains a table with the following data:

Parameter	Value
Loadcell CAN id	1
Loadcell cable diameter (mm)	0
Load measurement offset (kg)	0
Gain (-)	2000
Overload value (kg)	3300
Overload hysteresis (%)	50
Overload delay (ms)	200
Loadcell capacity (kg)	2000
Hoist capacity (kg)	3000
Additional gain factor (-)	1

Below the 'Safety Parameters' table is a 'Manual mode' toggle switch. Underneath, there are three buttons: 'Write', 'Bypass overload (140%)', and 'Deactivate bypass'. The 'Display parameters' section follows, containing a table with the following data:

Parameter	Value
Refresh time (s)	1
Value deviation	1
Resolution	100
Decimal shift	100

A 'Write' button is located below the 'Display parameters' table. At the bottom of the page, a status bar shows 'Connected', 'SWP Parameters', 'OEM', and 'Version 0.1 (oem)'.

7.9.1.1 Safety Parameter restrictions

Parameter	Description/Restrictions
Loadcell CAN id	The can id of the loadcell
Loadcell cable diameter (mm)	The diameter of the cable (mm)
Load measurement offset (kg)	Maximum 20% of loadcell capacity (unsigned 32-bit value)
Gain (-)	Between 400-20000 (factor 0.4 -20)
Overload value (kg)	Can be maximum 110% of Hoist capacity parameter (unsigned 32-bit value)
Overload hysteresis (%)	0-100%
Overload delay (ms)	0-1000
Loadcell capacity (kg)	Nominal capacity related to loadcell (unsigned 32-bit value)
Hoist capacity (kg)	(unsigned 32-bit value)
Additional gain factor (-)	Additional factor that can be applied if factor 20 of gain is not sufficient (default value 1)

7.9.2 Change parameters – automatically

When you select auto mode, you can automatically set the offset and gain to the right values.

Parameters

Safety Parameters

Loadcell CAN id	1
Loadcell cable diameter (mm)	0
Load measurement offset (kg)	0
Gain (-)	2000
Overload value (kg)	3300
Overload hysteresis (%)	50
Overload delay (ms)	200
Loadcell capacity (kg)	2000
Hoist capacity (kg)	3000
Additional gain factor (-)	1

Auto mode

Known load	-
-------------------	---

7.9.2.1 Offset

Make sure that the hook of your hoist is empty and completely down at its lowest position. Press **Set offset** to automatically subtract the remaining load from the measurement. The measured gross load should now be zero.

7.9.2.2 Gain

Hoist a known load (minimum 50% of hoist capacity). Fill in the Know load field and press **Set Gain** to automatically update the gain to match the calculated gross load to the known load.

7.10 Log (OEM/Dealer)

Additional functionality

- Delete logging

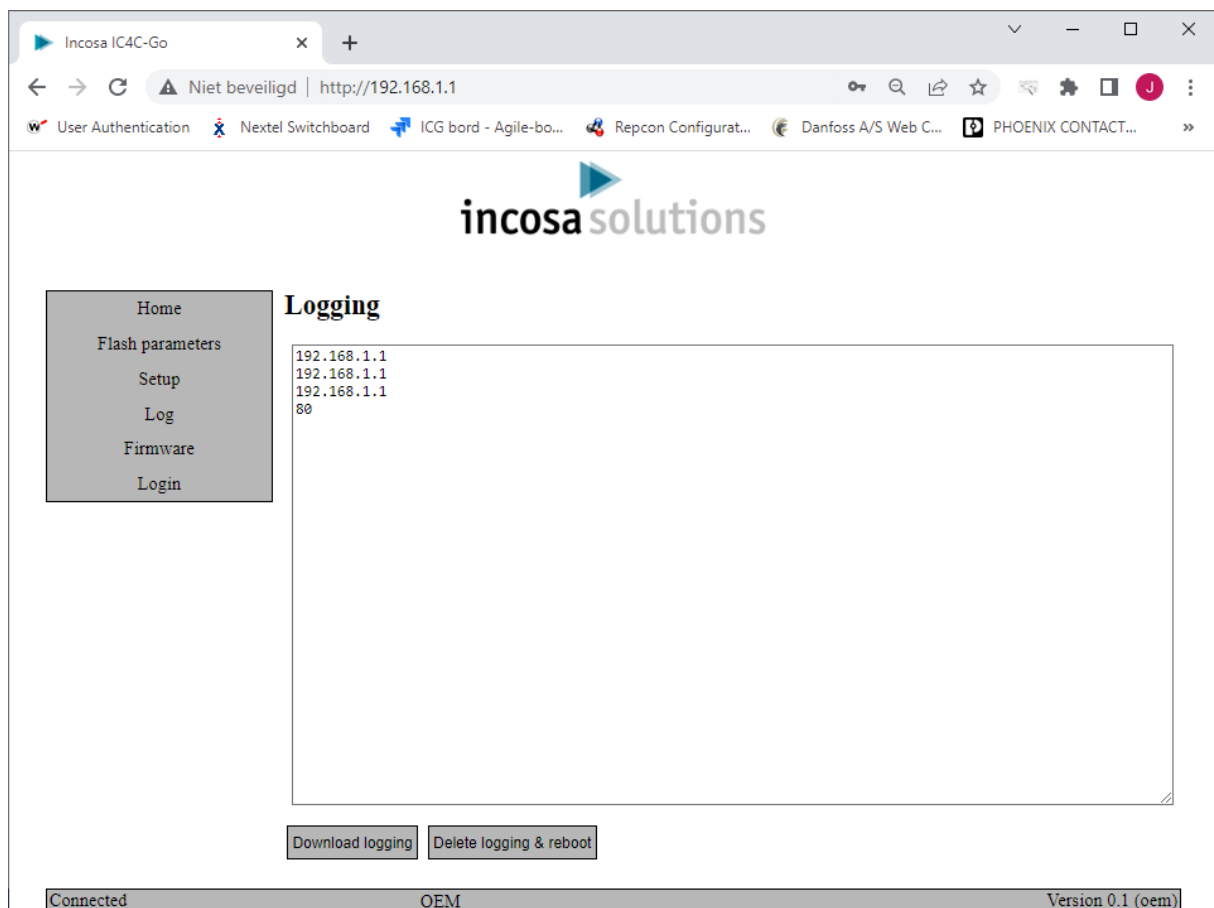

The screenshot shows a web browser window with the URL <http://192.168.1.1>. The page displays the Incosa Solutions logo and a navigation menu on the left with options: Home, Flash parameters, Setup, Log, Firmware, and Login. The main content area is titled "Logging" and contains a text box with the following log entries:

```
192.168.1.1
192.168.1.1
192.168.1.1
80
```

Below the log entries are two buttons: "Download logging" and "Delete logging & reboot". At the bottom of the page, a status bar shows "Connected", "OEM", and "Version 0.1 (oem)".

7.11 Firmware (OEM/Dealer)

This menu item is only available when logged in. You can select and upload a new firmware/configuration to the **i-C4C GO**. The module has two boot partitions. The new firmware will be uploaded to the inactive partition.

The active partition and the boot partition are displayed. You can change the boot partition to force the i-c4c to start with a different configuration already present in the other partition.

Warning

All action in this menu have large implication on the current behaviour of the **i-C4C GO**, therefore they should be controlled by qualified personnel.

The screenshot shows the 'Firmware' section of the Incosa IC4C-Go web interface. It features a navigation menu on the left with options: Home, Flash parameters, Setup, Log, Firmware, and Login. The main content area is titled 'Firmware' and 'Upload firmware'. It contains a 'Choose file' button, a 'Choose File' input field, an 'Upload & Flash' button, a progress bar, and a 'Reboot' button. Below this is a 'Switch between partitions' section with a dropdown menu set to 'ota_0' and a 'set boot partition' button. The 'Partitions Info' section displays a table with the following data:

Boot partition	ota_0
Running from partition	ota_0

Below the table is a section for 'ota_0' with a detailed table of properties:

label	ota_0
type	0
subtype	16
address	0x10000
size	1024 kb
encrypted	0
OTA State	2
magic word	2882360370
secure version	0
version	0.1.14
project name	IC4C-GO
time	09:39:30
date	Oct 25 2022

At the bottom of the interface, there is a status bar showing 'Connected', 'OEM', and 'Version 0.1 (oem)'.

7.11.1 Upload firmware

Click on **Choose file**, and select the new firmware file.

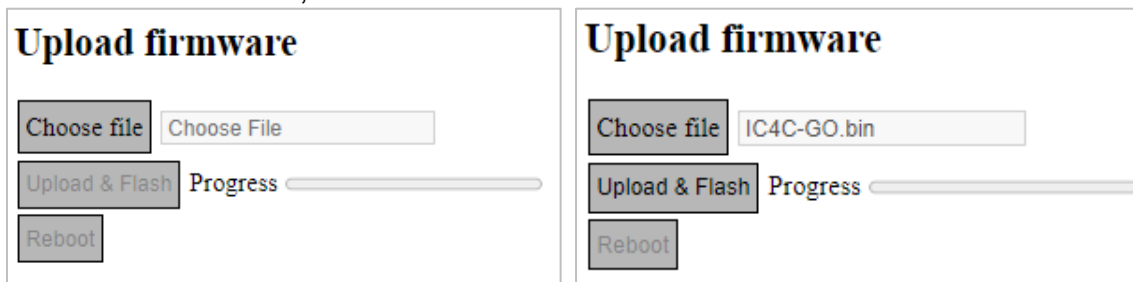

Click on **Upload & flash**, wait until the progress bar is full.

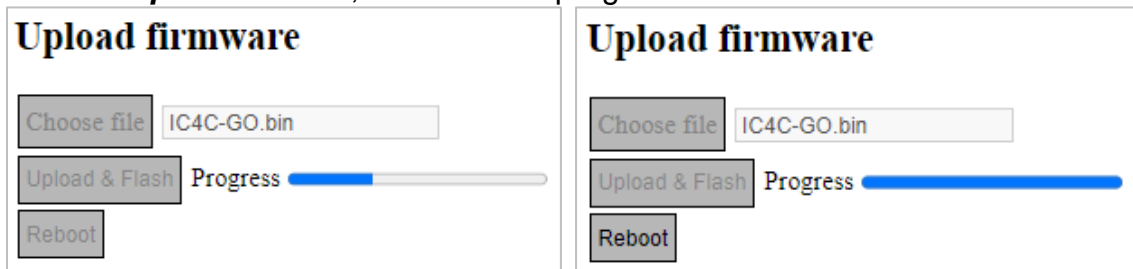

Remark

The upload speed might vary depending the connection quality. If the upload get stuck, power down the **i-C4C GO** and try the process again from start.

After a succesful upload the boot partion will be updated. Restart the **i-C4C GO** by clicking the **Reboot** button or by manually switching off the power to the **i-C4C GO**.

Partitions Info

Boot partition	ota_1
Running from partition	ota_0

When you go back to the firmware page after the reboot, the running partition should have been updated to match the new boot partition.

Partitions Info

Boot partition	ota_1
Running from partition	ota_1

8 Communication

Data communication (e.g. I/O's, values ...) between **i-C4C GO** modules in a network configuration is achieved by wire through CAN-bus. It is also possible to connect to a normal i-C4C or i-C4C RF module using CAN-bus.

Note

The i-C4C GO has two CAN-busses. The left CAN-bus is always used for the overload functionality and cannot be used for other applications. The right CAN-bus can be used for CAN-communication with other devices.

Note

The configuration of the wired network is set by the **i-C4C GO** dealer.

8.1 Architecture

8.1.1 Wired (CAN)

The wiring-topology of a CAN-network should be as close as possible to a single line structure in order to avoid cable-reflected waves. The total length of all the branches of the bus must not exceed 200 meters (650 ft.).

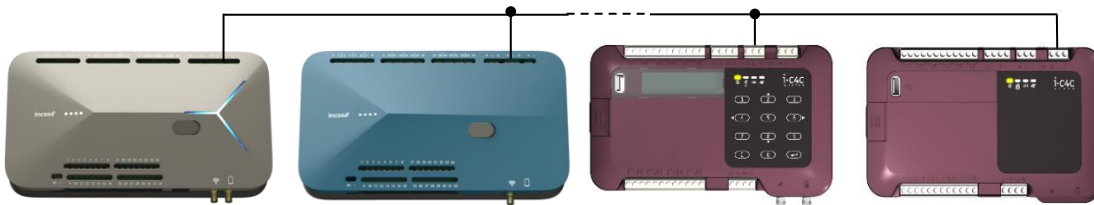

For a proper communication, terminating resistors R_T of 120Ω at each end of the bus are required to prevent reflections. The **i-C4C GO** includes an internal terminating resistor which can be enabled/disabled in software.

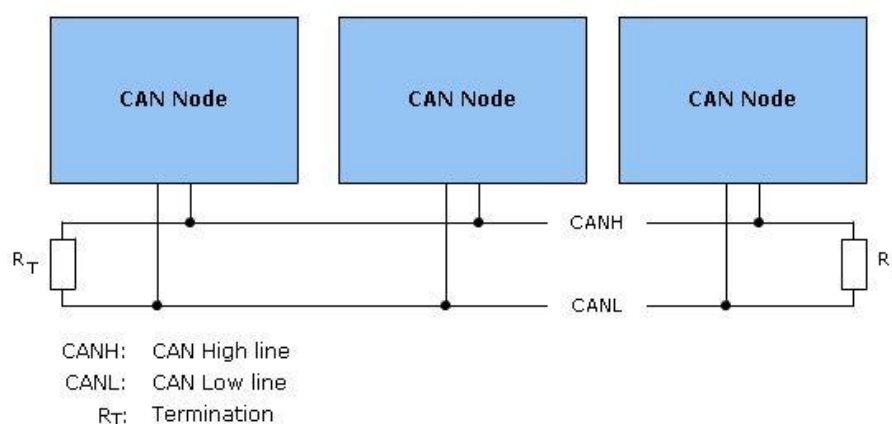

8.1.2 Wireless (Wifi)

i-C4C GO could be configured as accesspoint (default) or client on an existing network for wireless communication. Wifi standard 802.11b/g/n: up to 150 Mbps. Unlicensed band 2.4 GHz (2412~2484 MHz).

Mobile devices with wifi communication possibilities can connect with i-C4C GO modules. This gives the chance to interact with modules through web-browser tipping the IP address of i-C4C GO.

Functionalities:

- status visualization
- modification of parameters
- download log files
- upload configuration

9 Technical specifications

9.1 General data

Function	Description
Human interface	<ul style="list-style-type: none"> • wifi interface with webserver • status LEDs <ul style="list-style-type: none"> ○ 1: power ○ 2: CAN ○ 3: not used ○ 4: not used
Field of application	<ul style="list-style-type: none"> • load limiter PLd category 2 • summation • signal transmission (in combination with i-c4c RF)

9.2 Electrics/electronics

Function	Description
Digital inputs	<ul style="list-style-type: none"> • 22 optical isolated inputs • suitable for potential free contacts • suitable for direct activation (24VDC - if same source as module supply)
Digital outputs: Normal relays	<ul style="list-style-type: none"> • 11 relays, 1 NO contact, max 250VAC - 7A • galvanic insulated
Digital output: Overload	<ul style="list-style-type: none"> • 1 relay, 1 NO contact, max 250VAC - 7A Additional for PRO version in series: <ul style="list-style-type: none"> • 1 relay, 2 CO contacts, max 250VAC - 6A
Analogue outputs	<ul style="list-style-type: none"> • 1 analogue 0-10Vdc • resolution: 0-10000
Interfaces	<ul style="list-style-type: none"> • 1 CANOpen bus, 250 kbits/s, for overload • 1 CANOpen bus, different baud rates possible <ul style="list-style-type: none"> ○ 25/100/125/250/500/800/1000 kbits/s • 1 wireless Wifi • 1 Ethernet (Only on PRO model) • 1 Cloud connect (Only an option for PRO model)
Supply	<ul style="list-style-type: none"> • 24Vdc
Power consumption	<ul style="list-style-type: none"> • max 7,2W (Without Cloud connect)

9.3 Mechanical data

Function	Description
Dimensions (weight x height x depth)	<ul style="list-style-type: none"> • 238x130x52 mm (Basic) • 238x130x57 mm (Pro)
Mounting	<ul style="list-style-type: none"> • DIN rail 35mm
Weight	<ul style="list-style-type: none"> • 470g (Basic) • 510g (Pro)
Housing	<ul style="list-style-type: none"> • PC/ABS V0 (Housing) • PC V0 (LED guides) • TPR (Plugs)

9.4 Ambient data

Function	Description
Temperature range	<ul style="list-style-type: none"> • Components : -20°C to +85°C • Environment: -10°C to +60°C • Storage : -40°C to +85°C
Relative Humidity	<ul style="list-style-type: none"> • 5 to 85% (without condensing)
Maximum operating altitude above sea level	<ul style="list-style-type: none"> • 2000 m
Index of protection	<ul style="list-style-type: none"> • IP20

10 Annexe

10.1 Load cells

10.1.1 Connection

Color code to connect load cell to iC4C module:

red or brown	supply+ (24V)
Black or yellow	supply- (0V)
Green	signal+ (CAN H)
White	signal- (CAN L)

10.1.2 Load limiter on rope

Load limiter designed for measuring the tension on steel ropes that work on traction.

LMP 1 .. 7t

LMG 8 .. 40t

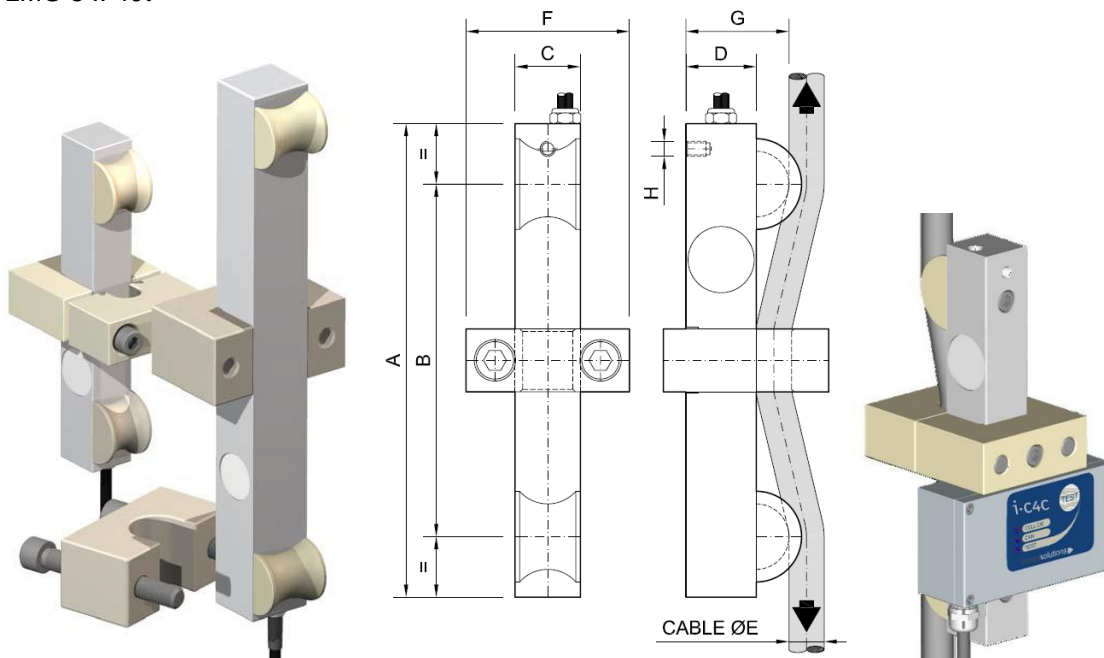

10.1.3 Load cell flexion

Load cells specially designed to work in jutting out with shear or flexion sensor element. Equipped with insulating cases of high mechanical resistance. CF 15...1500 kg.

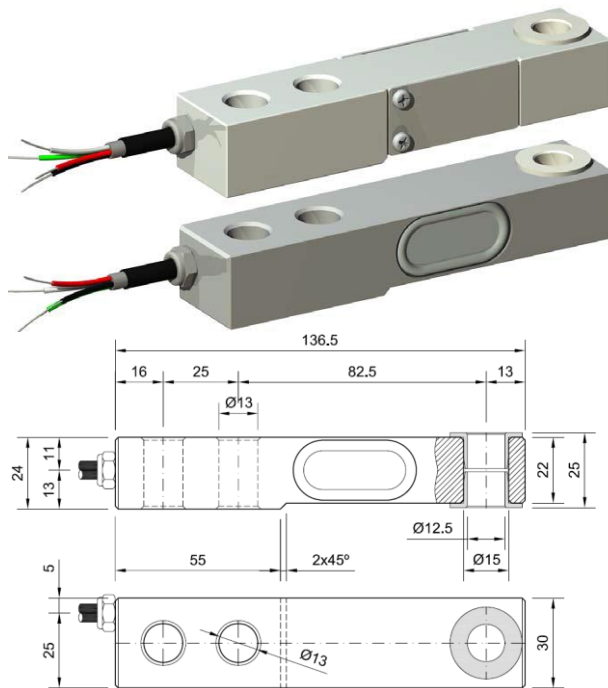

Dimensions in mm

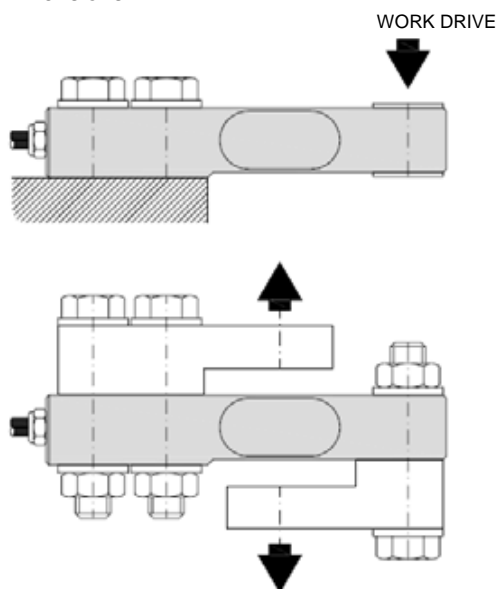

10.1.4 Double shear Load Pin

BULON DC

Load pin bulon type used in weighing system and load limitation.

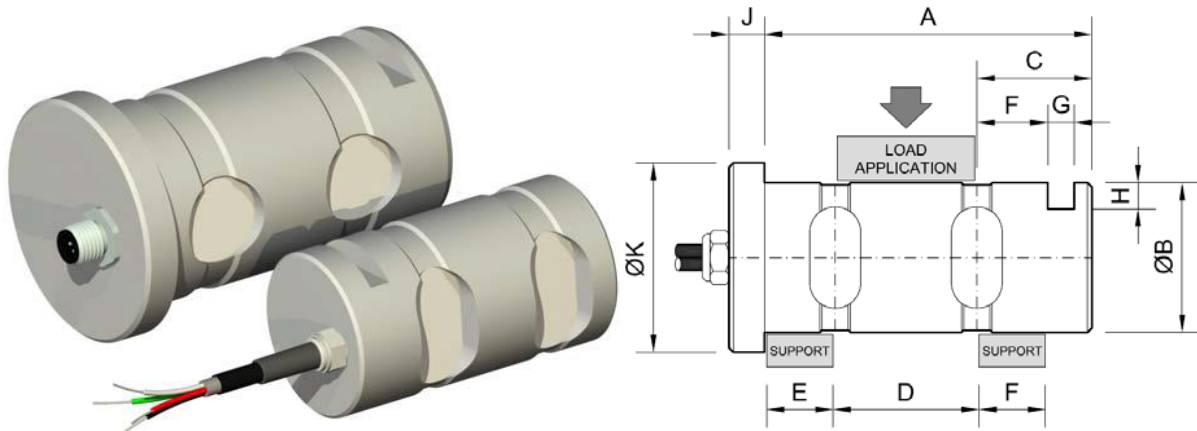

Optional outputs																																	
		4-20 mA	0-10 V	mV/V																													
		Zero range = 3.85 – 4.15	Zero range = 0-0.2 V	Zero tolerance = ± 0.1 mV/V																													
		Output with nominal load = 20 ± 0.3 mA	Output with nominal load = 10 ± 0.2 V	Sensitivity = 1.2 ± 0.3																													
		Excitation Voltage = 10..30 V	Excitation Voltage = 10..30 V	Maximum excitation Voltage = 24V																													
		Current consumption < 15mA	Current consumption < 15mA	Output impedance = 700 Ω																													
CONNECTIONS	CONNECTOR	<table border="1"> <tr> <td>+Vcc 10 ... 30</td> <td>1</td> <td rowspan="4"> </td> </tr> <tr> <td>N.C.</td> <td>2</td> </tr> <tr> <td>GND</td> <td>3</td> </tr> <tr> <td>4-20 mA</td> <td>4</td> </tr> </table>	+Vcc 10 ... 30	1		N.C.	2	GND	3	4-20 mA	4	<table border="1"> <tr> <td>+Vcc 10 ... 30</td> <td>1</td> <td rowspan="4"> </td> </tr> <tr> <td>N.C.</td> <td>2</td> </tr> <tr> <td>GND</td> <td>3</td> </tr> <tr> <td>0-10 V</td> <td>4</td> </tr> </table>	+Vcc 10 ... 30	1		N.C.	2	GND	3	0-10 V	4	<table border="1"> <tr> <td>+ Exc</td> <td>1</td> <td rowspan="5"> </td> </tr> <tr> <td>+ Signal</td> <td>4</td> </tr> <tr> <td>- Exc</td> <td>3</td> </tr> <tr> <td>- Signal</td> <td>2</td> </tr> <tr> <td>Shield</td> <td></td> </tr> </table>	+ Exc	1		+ Signal	4	- Exc	3	- Signal	2	Shield	
	+Vcc 10 ... 30	1																															
N.C.	2																																
GND	3																																
4-20 mA	4																																
+Vcc 10 ... 30	1																																
N.C.	2																																
GND	3																																
0-10 V	4																																
+ Exc	1																																
+ Signal	4																																
- Exc	3																																
- Signal	2																																
Shield																																	
	CABLE	<table border="1"> <tr> <td>+Vcc 10 ... 30</td> <td>RED</td> </tr> <tr> <td>N.C.</td> <td>WHITE</td> </tr> <tr> <td>GND</td> <td>BLACK</td> </tr> <tr> <td>4-20 mA</td> <td>GREEN</td> </tr> </table>	+Vcc 10 ... 30	RED	N.C.	WHITE	GND	BLACK	4-20 mA	GREEN	<table border="1"> <tr> <td>+Vcc 10 ... 30</td> <td>RED</td> </tr> <tr> <td>N.C.</td> <td>WHITE</td> </tr> <tr> <td>GND</td> <td>BLACK</td> </tr> <tr> <td>0-10 V</td> <td>GREEN</td> </tr> </table>	+Vcc 10 ... 30	RED	N.C.	WHITE	GND	BLACK	0-10 V	GREEN	<table border="1"> <tr> <td>+ Exc</td> <td>RED</td> </tr> <tr> <td>+ Signal</td> <td>GREEN</td> </tr> <tr> <td>- Exc</td> <td>BLACK</td> </tr> <tr> <td>- Signal</td> <td>WHITE</td> </tr> <tr> <td>Shield</td> <td></td> </tr> </table>	+ Exc	RED	+ Signal	GREEN	- Exc	BLACK	- Signal	WHITE	Shield				
+Vcc 10 ... 30	RED																																
N.C.	WHITE																																
GND	BLACK																																
4-20 mA	GREEN																																
+Vcc 10 ... 30	RED																																
N.C.	WHITE																																
GND	BLACK																																
0-10 V	GREEN																																
+ Exc	RED																																
+ Signal	GREEN																																
- Exc	BLACK																																
- Signal	WHITE																																
Shield																																	

10.2 μ CAN Converter

For use with the I-c4c GO, loadcells are provided with an internal μ CAN convertor.
Color code of connection cable of the load cell to the iC4C

red or brown	supply+ (24V)
black or yellow	supply- (0V)
green	signal+ (CAN H)
white	signal- (CAN L)

10.3 Antennas

10.3.1 Standard magnetic antenna 2dB



mounting position	any metallic surface [vehicle, computer, ...]
nominal impedance	50 Ohms
frequency	AMPS 824-868MHz ,GSM 900, 1800, 1900 MHz UMTS 2.1GHz, BLUETOOTH 2.4GHz
polarization	vertical
gain	5 dBi at 2.4GHz Bluetooth
vswr	<2:1
power handling	30W
cable	2.5m RG174
connector	upon request
housing size	238 mm x 31 mm
working temperature	-40 to +85 °C °C

10.3.2 Panel Directional Antenna 12dB



Wireless Antenna is a 2400 ~ 2483.5MHZ Panel Directional Antenna with 12dB with N-Type Female Connector and DC Ground Lighting Protection, which is designed for Outdoor WLAN Application. The Wireless Antenna is applied to link two Access Point between two locations such as two buildings or more. With all the features, ANT-112PN Wireless Antenna is an ideal device for 2.4G Wireless LANs, public wireless hotspot application and other multipoint applications where wide coverage is needed.

1. Panel Directional Antenna
2. Working on 2400MHz
3. High 12dbi gain to extend coverage
4. Provide wall mounting kit
5. Free angle

Electrical Specification	
Frequency	2400 ~ 2483.5MHZ
Type	Panel Directional
Polarization	Linear, Horizontal / Vertical
Gain	12dBi
VSWR	2.0:1
Beam Width	H-plane 50° E-plane 30°
Impedance	50Ω
Connector Type	N Type (Female) / N-type Female Reverse
Environmental & Mechanical Characteristics	
Temperature	-30 to 60°C
Lightning Protection	DC Ground
Radome	Injection ABS
Dimensions	166 x 140 x 30mm
Weight	594g

incosa¹

incosolutionsbv

Molenberglei 21 - B-2627 Schelle - BELGIUM
Tel: +32 3 451 93 95 | Fax: +32 3 887 30 61

commercial@incosolutions.com

www.incosasolutions.com

